

Complete Your Investment



ATS Systems : formerly ATS Workholding & SMW Systems

# ULTIMATE CHUCK QUICK JAW CHANGE POWER CHUCK

## MODELS UC2 & UC2-B

# Installation Operation and Maintenance Manual

### **WARNING**

Do not attempt to install, operate or perform maintenance on this product until you have read and completely understand the contents of of this manual.

For assistance contact:

**ATS SYSTEMS**

30222 Esperanza  
RSM, CA 92688  
P 800/321.1833  
800.423.4651  
F 949/888.8336  
[www.ats-s.com](http://www.ats-s.com)

**VERSION**  
**8.16.01**

## TABLE OF CONTENTS

### PRECAUTIONS

Summary of safety instructions	
Safety warning label	
Safety precautions	1.1 – 1.3

### SPECIFICATIONS

Specification data sheets and drawings	2.1
--	-----

### INSTALLATION

Installation procedure	3.1
Checking jaw stroke	3.2

### OPERATION

Basic operating points	4.1
Positioning base jaws in chuck	4.2
Use of half-pitch base jaws	4.3
Bolting top jaws to base jaws	4.4
Estimating safe chuck speed (RPM)	4.6

### MAINTENANCE

Disassembly and assembly of chuck	5.1
Lubrication	5.2
Spare Parts	5.3

### OTHER INFORMATION

Spare parts identification drawing and chart	6.1
Summary document for Operator training	6.2
ATS Systems Product Warranty	6.3

## Summary of Safety Instructions

1. Always follow all safety and maintenance instructions in this manual and all other standard safe shop practices.
2. All operating and maintenance personnel must be properly trained and qualified before operating, servicing, or repairing the ATS power chucking equipment.
3. Use this power chuck only for its intended purpose.
4. Chuck and workpiece must be protected by an adequate guard at all times when it is rotating.
5. The lathe should be equipped with a chuck actuating cylinder stroke control system and cylinder pressure control systems as described in this manual section 1.3.2.
6. The operation, lubrication, and maintenance safety warning label shown on the following page must be attached and prominently displayed on the lathe to which the power chuck is installed. Carefully heed all points including those relating to:
  - maximum RPM limits, use of excessive weight or height top jaws
  - proper top jaw mounting bolts
  - master base jaw position not extending beyond witness line / "safe" zone
  - lubrication
  - use of jaw change wrench
7. Take careful note of the sections of this manual marked with the following symbols:



**WARNING**

Danger of injury to personnel if instructions are not followed.



**ATTENTION**

Danger of damage to the machine or the power chuck if instructions are not followed.

## ATS Systems Ultimate Chuck Installation and Operations Manual



The following maintenance and safety warning label must be attached and prominently displayed on the lathe to which the Ultimate Chuck is installed.

### THE ULTIMATE CHUCK™ By ATS Systems (800) 423-4651

#### Recommended Operation, Lubrication & Maintenance For Models UC2 & UC2B Chucks

1. Read the Installation, Operation and Maintenance Manual.
2. Do not exceed RPM rating marked on the chuck or safe speed for the top jaw configuration or for the application, whichever is less. The maximum rated speed is only valid for maximum drawbar pull using the standard hard jaws model GUA designed for the chuck. For all other conditions speed must be reduced. Failure to do so may have catastrophic consequences. (See manual)
3. Do not use top jaws of excessive weight, height, or extended beyond the outside diameter of the chuck. See Manual for more specific guidelines.
4. Insure top jaw mounting bolts are grade 12.9, in new condition and the proper length for a minimum thread engagement of two times the thread diameter.
5. Inside end of base jaw must never be extended outward beyond the witness line or "SAFE" zone marked on face of chuck. (See manual)
6. Set jaw adjustment to grip the part as close to the start of the jaw stroke as possible, especially when chucking irregular castings, forgings, etc. As you chuck each part, observe that adequate jaw stroke remains to grip the part.
7. Use only ATS Systems' KO5 grease (Part #1113-9101). Grease chuck every 24 hours of operation, two shots of KO5 per grease fitting with the chuck in the full "open-jaws out" position.
8. At the start of each shift and after every 50 clamping cycles, actuate the chuck full stroke 5-10 times without gripping a workpiece to internally redistribute grease throughout the chuck.
9. Clean jaw guide ways when changing jaws, or at least once per shift if no jaw change is required, and lightly coat sliding jaw surfaces with KO5.
10. Do not exceed the maximum allowable drawbar pull.
11. Test chuck and record grip force at least once per month. If baseline grip force decreases more than 15%, the chuck should be disassembled, cleaned, and all internal parts coated with a film of KO5.
12. Never remove your hand from the jaw changing wrench - it could fly out if the chuck is rotated. Never actuate the chuck with the wrench inserted - severe internal chuck damage will occur.

# ATS Systems Ultimate Chuck Installation and Operations Manual

## PRECAUTIONS:

### SAFETY

Many sections in this manual deal with the issue of safety. Safe operation of CNC lathes and workholding is the responsibility of the user. The manufacturer of the Ultimate Chuck has used the latest technology in the design and manufacturing of this product. Careful consideration has been given to safety, and the authors of this manual make many recommendations regarding safe operation and safe chucking practices. The user of the lathe and chuck are responsible to understand these safe practices and precautions and to implement them into the operation and maintenance of the equipment.

All who use or maintain this equipment must have read, understand, and follow all instructions in this manual and other normal safe shop practices.

Maintenance and repair work must be done only by personnel who have been properly trained. It is the responsibility of the buyer/user of this equipment to ensure all appropriate training is received.

### 1.1 Safety Precautions

#### 1.1.1 The Ultimate Chuck by ATS Systems

This power operated chuck complies with all specific and general safety regulations valid at the time of delivery. Safe operation requires it be used only in proper applications with all necessary user precautions including but not limited to those specified below.

#### 1.1.2 Use for Intended Purpose

The safe function of the power chuck is, as far as can be foreseen, guaranteed when being used for its intended purpose in accordance with appropriate safety regulations.

Improper use of the power chuck can result in

- Danger to life and limb of the operator
- Danger to the power chuck and to the machine tool

**Unintended and improper use** of the power chuck includes, for example:

- Workpieces that are not clamped properly
- Safety regulations that are disregarded
- A chuck being used for machines or applications for which it is not intended
- Too large of a jaw being used especially if the speed is excessive for the size of the jaw.
- Any use of a chuck that has not been properly installed, maintained, and lubricated.



### WARNING

Improper or unintended use of the power chuck, and disregard of safety standards and safety regulations

**can threaten life and limb of the operator!**

### 1.1.3 Technical Conditions

The power chuck should only be used if it is in perfect condition, for its intended purpose, with total awareness of safety and hazards, and in accordance with all appropriate regulations.

In the event any faults are recognized, they must be eliminated immediately!

### 1.1.4 Use

The power chuck is intended solely for the use as agreed in the contract between the manufacturer/supplier and the user. Any other or further use is regarded as unintended. The manufacturer/supplier is not liable for any damage resulting from misapplication and unintended use. All risk is borne entirely by the user.

Intended use includes due regard of the appropriate operating and maintenance instructions and compliance with the inspection and maintenance requirements.

# ATS Systems Ultimate Chuck Installation and Operations Manual

## 1.2 Users Organizational Requirements

### 1.2.1 Compliance with Regulations

The user must ensure that suitable actions in organization and instruction are taken to ensure that all appropriate safety rules and regulations are complied with by the persons entrusted with operation, maintenance and repair of the power chuck.

### 1.2.2 Supervision of Chuck Operators

The user is required to routinely check their personnel's conduct regarding awareness of safety and hazards, and the safe and proper use of the chuck.

### 1.2.3 Hazard Notices

The user must ensure that the warning labels regarding safety and hazards for the machine to which the power chuck is mounted are observed and that the warning labels are clearly legible.

### 1.2.4 Defects, faults, hazardous conditions

If faults occur at the chuck which affect safety, or production indicates that faults are in existence, then the machine to which the power chuck is mounted must be brought to a complete and immediate stop for as long as is required to locate and eliminate the fault.

Faults may only be eliminated by trained and authorized personnel.

### 1.2.5 Modifications

Do not make any alterations, add any fixtures or carry out any modifications to the power chuck which could affect safety without the prior agreement of the supplier.

This also applies to the installation of safety devices.

### 1.2.6 Spare Parts

Only use spare parts which meet the requirements of the manufacturer. This is guaranteed only if original spare parts are used.

Improper repair or use of incorrect spare parts will result in the manufacturers and suppliers exclusion from product liability.

### 1.2.7 Periodic Inspection

Follow the instructions in this manual and carry out the required routine inspections and service at the time intervals specified.

### 1.2.8 Choice of Personnel, Personnel qualifications

- Work on/with the power chuck may only be done by qualified personnel.
- Allow only personnel that have been properly trained to operate the power chuck. ATS offers training programs.
- Clearly define the areas of responsibility for all personnel for operation, maintenance and repair.
- Allow only personnel that are well informed of the safety requirements to carry out maintenance and repair work on the power chuck.
- Make it clear to the operator his responsibility for safety conscious conduct. Enable him to refuse instructions by third parties which are irresponsible with regard to safety.

## 1.3 Product Safety Notes

### 1.3.1 Important!

These operating instructions are only valid for the model UC2 and UC2B power chucks.

The recommended maximum speed given is only valid for maximum draw bar pull using the standard stepped hard jaws model GUA or GST designed for the chuck, and only for a chuck that has been properly maintained and lubricated.



### WARNING

During machining, testing, and set up or whenever the chuck is rotating, the chuck and the clamped workpiece must at all times be protected by an adequate guard.

# ATS Systems Ultimate Chuck Installation and Operations Manual

**Excessive top jaw weight must be avoided!** Pay careful attention when designing or using soft jaws or special jaws. Jaw weight, their distance from centerline and the RPM of the lathe dramatically effect remaining chuck grip force during chuck rotation. In extreme cases of unsafe use it may even be possible for the top jaws themselves to fly off the chuck. See this manual section 1.3.6 and 4.6 for more information.



## WARNING

**Avoid standing directly in line with a rotating chuck or workpiece!** It is good safety practice to assume the lathe's guard may not prevent a thrown workpiece or broken top jaw fragment from penetrating the guard.

### 1.3.2 Safety when installing the Chuck

**When installing a chuck and/or a cylinder to a lathe, the following technical safety requirements must be observed:**

- The lathe should be equipped with safety systems that prevent the spindle from rotating unless the clamping pressure has built up in the cylinder and clamping of the chuck has been confirmed by a feedback system.
- The lathe should be equipped with safety systems so that unclamping is only possible when the machine spindle has come to a complete stop.
- The lathe and clamping cylinder should be equipped with safety systems so that in the case of a failure in the supply of pressure to the cylinder, the workpiece remains securely clamped until the spindle has come to a complete stop.
- The lathe should be equipped with safety systems so that in the case of a power failure and re-supply, the lathe will not restart without new commands from the lathe operator.
- **Stroke control!** The lathe should be equipped with a safety system that monitors the stroke of the actuating cylinder piston and prevents the

lathe spindle from rotating unless a workpiece is properly clamped. One recommended system provides a safety zone at the front and rear most portion of the piston stroke. For the lathe spindle to rotate, the piston must be somewhere between the front and rear safety zones which is only possible if a workpiece is clamped. **Caution:** Whenever the chuck is removed for maintenance or any other reason, then reinstalled, the stroke control switch adjustments must be checked and readjusted if necessary.

### 1.3.3 Inspecting chuck function and performance

After installing the power chuck, its function and performance must be checked.

- **Clamping Force!** The clamping force of the chuck and cylinder system must be checked with a grip force gauge. Refer to the chuck and cylinder specifications, note the hydraulic or pneumatic operating pressure, calculate the expected grip force and confirm the actual performance with the grip force gauge. If it does not match within 10%, do not use the system until the cause is determined and corrected. **Important:** When using other than standard factory hard jaws, the grip force should be checked with a dynamic grip force gauge at the planned operating speed (RPM) to insure there is adequate grip force remaining to hold the workpiece. Start the inspection at a low speed and build up to the operating speed while observing the gauge. (Note: Estimated grip force loss at speed can be calculated to establish parameters for actual testing with a dynamic grip force gage. See this manual section 4.6) **Jaws should never be positioned to extend beyond the outside diameter of the chuck more than the standard amount as described for the standard base jaws in the ATS technical specifications.**

# ATS Systems Ultimate Chuck Installation and Operations Manual

## 1.3.4 Chuck Rotational Speed (RPM)



### WARNING

If the maximum speed of the lathe is greater than the maximum recommended speed of the chuck and/or the clamping cylinder, the machine must be equipped with a speed limiting device.

The centrifugal force acting on the clamping jaws must be considered when determining the required clamping force to machine a workpiece. See section 1.3.3 above and section 4.6.

## 1.3.5 Maintenance Instructions

The reliability of the chuck can only be guaranteed if the maintenance requirements in these operating instructions are followed exactly. In particular, attention must be paid to:

- Lubrication: Only ATS K05 grease (Part #1113-9101) should be used. (Unsuitable lubricants can reduce the clamping force by more than 50%). The chuck should be greased each **24** hours of operation under normal conditions. (See 5.2.3)
- All surfaces that require lubrication must be reached. (The close fits of mating parts require a high injecting pressure. For this reason a high pressure grease gun should be used). **Important:** Grease must be injected into the three fittings on the face of the chuck when the chuck jaws are fully opened (jaws outward from centerline). **It is only in this position that lubrication will properly reach the internal components of the chuck.**
- To ensure good grease distribution, inject one shot of grease into each of the three grease fittings, actuate the chuck full stroke several times, and then inject a second shot of grease into each of the three fittings. Check the clamping force with a grip force gauge.
- After each **50** clamping strokes it is advisable to actuate the chuck several times without gripping a workpiece so that the chuck is stroked to its extreme limits. When this is done, lubricant that has been displaced is returned to the pressure

surfaces and the clamping force is retained for a longer period of time without re-lubrication.

- Depending on the application and the workpiece materials being machined, the chuck will periodically need to be disassembled and cleaned. After cleaning, all internal parts must be coated with a film of KO5 grease, and the chuck body cavities at either end of the wedge bars filled 50% with KO5 grease. Each time the chuck is actuated and the wedge bars stroke, this “reservoir” of grease is pumped back through ports in the wedge bar to lubricate critical surfaces.
- Ultimate Chucks were designed primarily for JIT applications with frequent jaw changeover. No grease fitting ports lubricate the jaw guide ways. Whenever jaws are changed, inspect the chuck guide ways for cleanliness and put a film of grease on the sliding surfaces of the master base jaws before inserting them into the chuck. For high volume production applications when jaws aren’t changed frequently, the jaws should be removed once per shift (depending on machining cycle time), cleaned and re-lubricated.
- It is recommended that the clamping force be checked using a grip force gauge before beginning a new production batch and between maintenance checks. Only regular checks can guarantee safety.

## 1.3.6 Use of Special Design jaws

When using special design jaws the following rules must be observed:

- The jaws should be designed to be as light and as low as possible. The clamping point should be located as close to the chuck face as possible. (Clamping points with greater distances cause increased surface pressure in the jaw guides and can reduce clamping force substantially).
- If the design of the special jaws requires them to be wider and/or higher than the standard factory stepped jaws designated for the chuck, then it is important to consider the higher centrifugal forces involved when calculating the resulting clamping force and maximum speed allowed with these jaws. **Caution:** Jaws should never be positioned to extend beyond the outside diameter of the chuck more than the standard amount as described for the standard base jaws in the ATS

# ATS Systems Ultimate Chuck Installation and Operations Manual

technical specification. **Caution:** Jaws should never extend from the face of the chuck a distance more than 30% of the diameter measurement of the chuck. Excessively tall jaws that are operated with either high grip force or high speed or a combination of speed and grip force can over stress the bolts that hold the top jaw to the base jaw.

- Do not use welded jaws.
- The mounting bolts must be arranged in such a way as to ensure that greatest possible strength is achieved.
- The maximum recommended speed may only be used in conjunction with maximum draw bar pull, only with chucks that are in perfect working order, and only with standard hard jaws positioned within the chuck diameter (or equivalent jaw and diameter) .
- After a crash, the chuck must be examined for cracks and other damage, and grip performance inspected before being put back into operation. Damaged parts must be replaced with original ATS spare parts.
- Top jaw mounting bolts must be replaced if they show signs of wear or damage. Only use grade 12.9 bolts of sufficient length to engage at least a thread length equal to 1 ½ - 2 times the screw diameter.

### 1.3.7 Safety during Maintenance

Follow all normal safety precautions when performing maintenance on the chuck or any portion of the machine tool, such as turning off the electrical power and locking out electrical service, wearing safety equipment, etc.

Only operate power chucks when all safety guards have been installed and are in full working order.

Check the power chuck at least once per shift for externally visible damage and faults.

Report any changes including changes in operational behavior to the responsible persons immediately. If necessary bring the spindle to an immediate stop and lock out the electrical supply.

Only restart the machine to which the power chuck is installed when the cause of the problem has been eliminated.

### 1.3.8 Notes on Instruction of Operating Personnel

We recommend that the user of our power chucks make the operating instructions, in particular the “Precautions” section, available to all persons who will be operating, maintaining or repairing the chuck or the machine tool to which it is installed. We further recommend that the owner issue “operating instructions” which consider the qualifications of the operating personnel known to him.

Participation in training programs and courses etc. with the aim of gaining knowledge in operation, maintenance and repair of the power chuck should be confirmed in writing for the business operator. For this purpose we recommend duplicating and using the following form.

#### Declaration of knowledge by Personnel (Operator)

It is confirmed herewith that the person of

---

Mr./Mrs./Miss

being charged by the business operator with responsibility to operate chucking equipment has read and understands the operating instructions, in particular the section on “Precautions”, for the ATS power chuck.

---

Operator Date

---

Business Operator/  
Authorized person Date

# **ATS Systems Ultimate Chuck Installation and Operations Manual**

## **SPECIFICATIONS:**

### **2.1 Specifications and dimensions**

The following pages in this section include drawings and specification data sheets for both chuck models that direct mount to A-type lathe spindle noses, and models that require an adapter plate between the chuck and the lathe spindle nose. The data sheets show all models that are possible, but not all models are regularly stocked.

## Ultimate Chuck Model UC 2 Direct Mount Models

Model		170-45		210-52		225-68		265-77		315-91		400-128		500-155	
Diameter	A	170		210		225		265		315		400		500	
Thru hole	B	45		52		68		77		91		128		155	
Piston stroke	C	18		20		20		28		28		30		35	
Stroke/jaw	D	5.6		6.3		6.3		8.8		9.1		9.8		11.4	
Jaw adjust pitch		4.8		4.8		4.8		5.5		5.5		5.5		7.0	
Max RPM		6300		6000		5500		4700		4000		3500		2200	
Max drawbar pull	daN	3300		5000		5000		7300		10000		13300		13300	
	Lb	7400		11200		11200		16400		22400		29900		29900	
Total grip force	daN	6000		9500		9500		13500		18000		24000		23500	
	Lb	13500		21300		21300		30300		40500		54000		52900	
Weight w/o jaws	Kg	18		25		26		47		67		113		225	
	Lb	39		55		58		104		148		249		495	
Max. drawtube thread	E	M52x1.5		M60x1.5		M78x1.5		M85x1.5		M100x2		M138x2		M165X2	
	E1	57		66		84		91		115		125		160	
Min. adapter length	F	17		18		18		22		25		29		29	
Spindle nose		A5	A6	A6	A8	A6	A8	A6	A8	A8	A11	A11	A15	A11	A15
Length	H	99	101	115	117	115	117	136	138	146	148	156	157	180	181
	I	17	21	18	24	18	24	17	24	26	24	28	36.5	30	37
	J	105.7	107.7	119.9	121.9	119.9	121.9	144.5	146.5	155	157	165	166	190	191
	K	16	17	17	18	17	18	17	19	19	21	21	23	21	23
Max Min	L	32	34	36	38	36	38	43	45	45.5	47.5	49.5	50.5	54.5	55.5
		14	12	16	18	16	18	15	17	17.5	19.5	19.5	20.5	19.5	20.5
	M	104.8	133.4	133.4	171.4	133.4	171.4	133.4	171.4	171.4	235	235	330.2	235	330.2
Bolt thread	N	M10	M12	M12	M16	M12	M16	M12	M16	M16	M20	M20	M24	M20	M24
	O	M64x1.5		M75x1.5		M92x1.5		M98x1.5		M120x1.5		M160x2		M188x2	
	P	70		85		100		108		130		175		207	
Base jaw	R	65		85		85		104		115		125		160	
Maximum safe jaw position	X	26.2		39.7		47.8		50.9		59.9		86.5		100.9	
Max Min	a	72.2	101.7		109.8		128.9		148.9		181.5		225.9		
		58.1	78.5		68.3		95.9		95.9		121		155.9		
	b	18		20		20		20		20		26		30	
Jaw width	e	20		22		22		26		32		32		45	
	e1	8		10		10		12		12		12		18	
	e2	20		22		22		26		32		32		45	
	f1	M6		M6		M6		M8		M8		M8		M8	
	f2	M8		M8		M8		M10		M12		M16		M20	
	g1	75		94		100		124		140		170		200	
	g2	142		190		205		220		268		330.2		420	
	h1	60°		60°		60°		60°		60°		60°		60°	
	h2	35°		70°		65°		77°		77°		70°		77°	
	j1	40°		39°		39°		30°		40°		42.5°		30°	
	j2	50.5°		49°		49°		40°		45°		45°		45°	
Bolt thread	k	M8		M8		M12		M12		M12		M16		M16	

Specifications subject to change without notice. Contact SMW Systems for the latest specifications and dimensions. Not all models shown are available from stock.

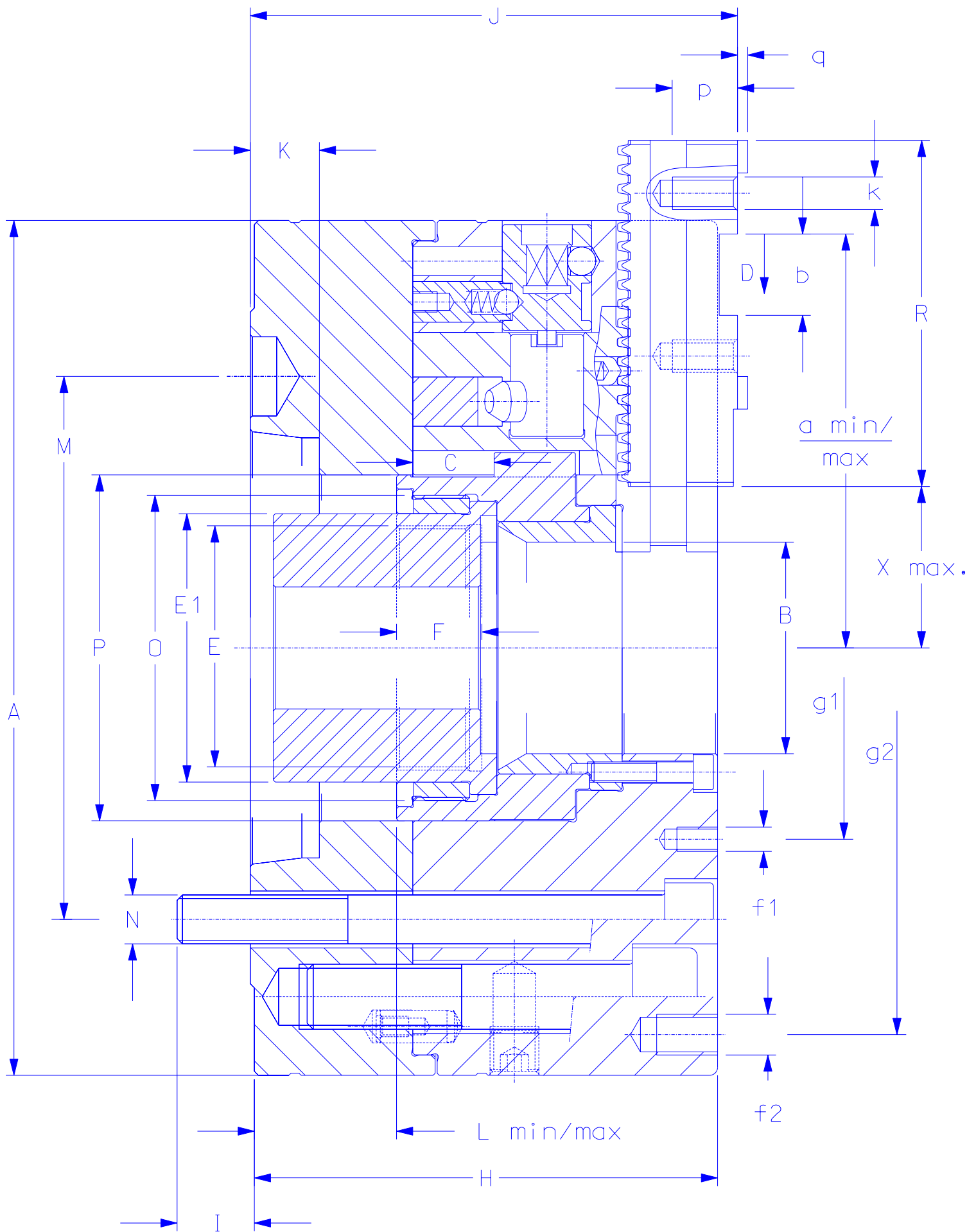

DIRECT MOUNT & ADAPTER MODELS

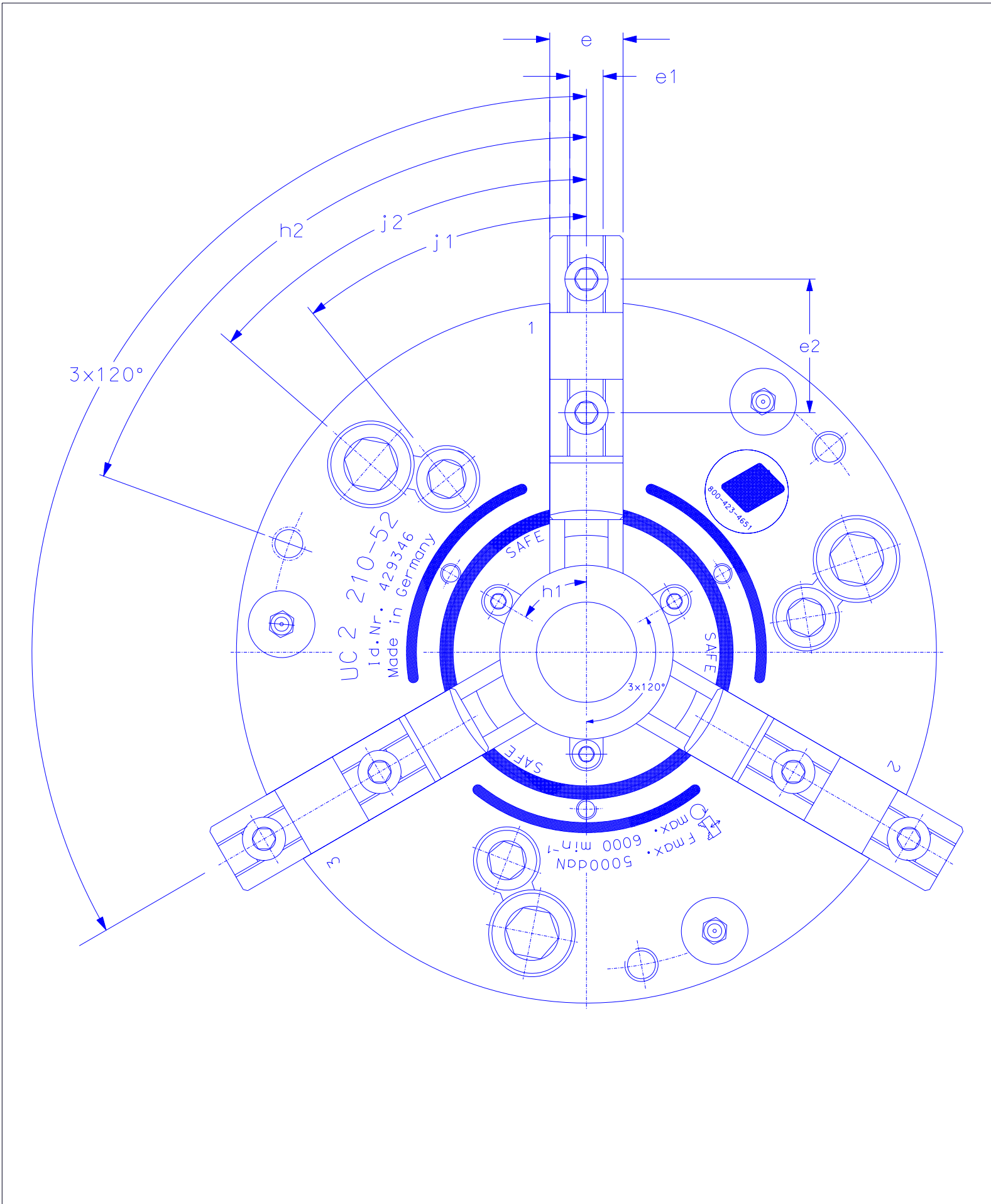

## Ultimate Chuck Model UC 2

### Plain-Back Adapter Plate Mounted Models

Model		210-52	225-68	265-77		315-91		400-128		500-155	630-167
Diameter	A	210	225	265		315		400		500	630
Thru hole	B	52	68	77		91		128		155	167
Piston stroke	C	20	20	28		28		30		35	40
Stroke/jaw	D	6.3	6.3	8.8		9.1		9.8		11.4	12.6
Jaw adjust pitch		4.8	4.8	5.5		5.5		5.5		7.0	7.0
Max RPM model UC2		6000	5500	4700		4000		3500		2200	1700
Max RPM model UC2B		5000		4000		3500		2750		1800	1500
Max drawbar pull	daN Lb	5000	5000	7300		10000		13300		13300	13300
		11200	11200	16400		22400		29900		29900	29900
Total grip force	daN Lb	9500	9500	13500		18000		24000		23500	23500
		21300	21300	30300		40500		54000		52900	52900
Weight w/o jaws	Kg Lb	25	26	47		67		113		225	383
		55	58	104		148		249		495	845
Max. drawtube thread	E	M60x1.5	M78x1.5	M85x1.5		M100x2		M138x2		M165X2	M180x2
		E1	66	84	91		115		125		160
Min. adapter length	F	18	18	22		25		29		29	35
Adapter pilot	G	170	170	170	220	220	300	300	380	380	520
Length	H	101	101	122	122	130	130	138	138	162	179.5
		I	17	17	21	25	22	27	26	35.5	37
	J	105.9	105.9	130.5	130.5	149	149	147	147	172	189.5
	K	6	6	6	6	6	6	8	8	8	8
Max Min	L	22	22	29	29	29.5	29.5	31.5	31.5	36.5	41.5
		2	2	1	1	1.5	1.5	1.5	1.5	1.5	1.5
	M	133.4	133.4	133.4	171.4	171.4	235	235	330.2	330.2	463.6
Bolt thread	N	M12	M12	M12	M16	M16	M20	M20	M24	M24	M24
		O	M75x1.5	M92x1.5	M98x1.5		M120x1.5		M160x2		M188x2
	P	85	100	108		130		175		207	235
Base jaw	R	85	85	104		115		125		160	200
Maximum safe jaw position	X	39.7	47.8	50.9		59.9		86.5		100.9	120.4
Max Min	a	101.7	109.8	128.9		148.9		181.5		225.9	285.4
		78.5	68.3	95.9		95.9		121		155.9	187.4
	b	20	20	20		20		26		30	30
Jaw width	e	22	22	26		32		32		45	45
		e1	10	10	12		12		12		18
	e2	22	22	26		32		32		45	45
	f1	M6	M6	M8		M8		M8		M8	M8
	f2	M8	M8	M10		M12		M16		M20	M16
	g1	94	100	124		140		170		200	245
	g2	190	205	220		268		330.2		420	520
	h1	60°	60°	60°		60°		60°		60°	60°
	h2	70°	65°	77°		77°		70°		77°	77°
	j1	39°	39°	30°		40°		42.5°		30°	45°
	j2	49°	49°	40°		45°		45°		45°	60°
Bolt thread	k	M8	M8	M12		M12		M12		M16	M16

Specifications subject to change without notice. Contact ATS Systems for the latest specifications and dimensions. Not all models shown are available from stock.



# ATS Systems Ultimate Chuck Installation and Operations Manual

## INSTALLATION:

### 3.1 Installing the chuck to the machine spindle

See 6.1 in OTHER INFO section of this manual for parts identification.

#### 3.1.1 Checking the chuck and machine spindle

- Check the machine's spindle nose and flange, or the finished machined adapter plate concentricity and face runout. Maximum allowable runouts are 0.005 mm.
- All mating surfaces must be clean and free of nicks, dents, chips, dirt, etc.

#### 3.1.2 Installing the chuck

- Remove the chuck from the package, check for damage and that it is complete.
- If there are any base jaws installed in the chuck, unlock and remove them. (see this manual section 4.1).
- You need to determine the actual maximum stroke of your hydraulic cylinder and drawtube. Actuate the cylinder and extend the drawtube fully forward. Using calipers, measure from the end of the lathe spindle nose to the front of the drawtube and record the dimension. Now actuate the cylinder and fully retract the drawtube and record the measurement from the same point on the spindle nose to the same point on the end of the drawtube. Subtract these two numbers and record here the actual drawtube stroke for future reference.

**Cylinder stroke** = \_\_\_\_\_

- Actuate the cylinder so that the drawbar/drawtube once again extends fully forward. (see figure 3.1).
- Push the chuck piston into its forward most position.
- Confirm R2 dimension is .010" - .080" less than R1 dimension measured to the inside bottom of the drawtube adapter. If R2 is not shorter than R1 **STOP** and rework the drawtube adapter if possible or shorten the drawtube.

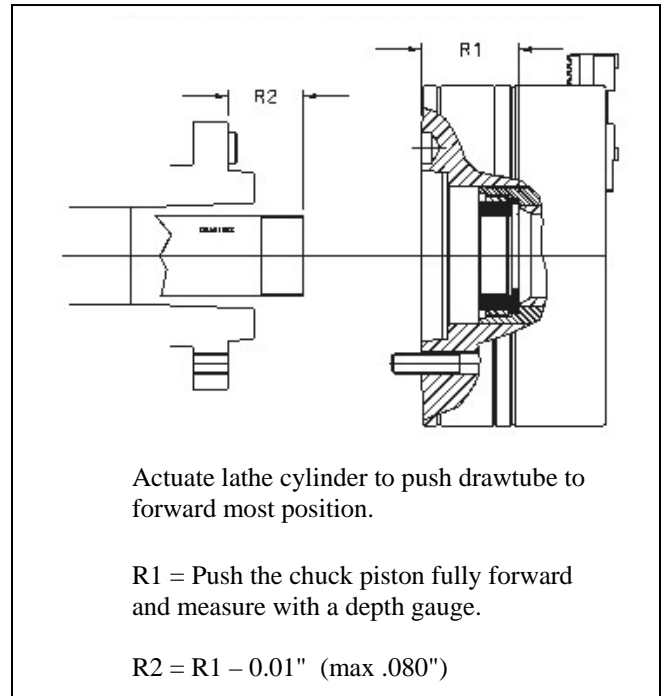

Fig 3.1

- Use supplied T-wrench (60) to tighten drawtube adapter retaining ring (5) with drawtube adapter (4) in place in chuck. Confirm drawtube adapter is free to rotate but has less than .008" of end play (allowable drawtube Z axis free motion). Rework drawtube adapter if necessary. Remove drawtube adapter retaining ring and remove drawtube adapter. Screw drawtube adapter fully onto drawtube to confirm tread fit.
- Put a small amount of never-seize or grease on the front and the rear of the drawtube adapter flange (not on the threads). Put the drawtube adapter into the chuck keeping the never-seize off of the threads. Install drawtube adapter retaining ring with several drops of thread-locker and tighten retaining ring with T-wrench. (Don't use excessive thread-locker.)
- Coat threads on drawtube and drawtube adapter with never-seize. Using a sling or a lifting eye bolt, hold the chuck in alignment with the center of the spindle in front of the spindle nose.

# ATS Systems Ultimate Chuck Installation and Operations Manual

- Using the supplied T-wrench (51), rotate the threaded draw tube adapter bushing in the chuck fully onto the drawtube or drawbar.
- Actuate cylinder to close the chuck. Tighten the chuck mounting bolts in a crosswise pattern. Torque bolts to specification.

M12	85 ft-lb	½-13	90 ft-lb
M16	190 ft-lb	5/8-11	190 ft-lb
M20	365 ft-lb	¾-10	365 ft-lb
M22	520 ft-lb	7/8-9	560 ft-lb
M24	660 ft-lb	1"-8	800 ft-lb

- Check the chuck concentricity on the O.D. indicating surface, and face runout.
- Check the operation of the drawbar/drawtube.
- Actuate the cylinder so that it reaches its forward most position (jaw open). Using T-wrench (51), unscrew drawtube adapter (counterclockwise) until chuck actuator (3) reaches it's forward most position and then turn the T-wrench back clockwise a quarter turn.
- Unlock the wedge bar using special hex wrench (47) and insert the base jaws which are marked 1,2, and 3 into the chuck jaw guideways with the corresponding number. (See this manual section 4, Operation)

**Note:** If the special T-handled hex wrench will not turn easily, the drawbar/drawtube assembly is too short. This condition may be corrected by rotating the drawtube adapter bushing counter clockwise. Be sure there is sufficient thread engagement after any adjustment.

**Note:** If the jaws become tight when changing jaws and sliding them to the chuck center, the drawtube assembly may be too long which can be corrected by rotating the drawtube adapter bushing clockwise.

Exact drawtube adjustment is important to ensure full jaw stroke. Be sure the drawtube doesn't bottom out in the chuck when forward and that an adequate number of threads are engaged between the drawtube and the drawtube adapter.

- Actuate the cylinder and check that the base jaws move smoothly and that the jaw stroke is correct.

- With calipers, measure actual stroke per jaw and record here

**Actual jaw stroke per jaw = \_\_\_\_\_**

Removing the chuck is done in the reverse order.

### 3.2 Calculate theoretical jaw stroke for this cylinder and compare to actual measured jaw stroke.

Generally speaking, the Ultimate Chuck has longer jaw stroke than most power chucks but requires longer piston stroke than simple wedge-hook chucks to achieve full jaw stroke. Even when using the same shorter piston stroke as simple wedge-hook chucks, the Ultimate Chuck's shortened jaw stroke might be longer than the simple chuck. But this jaw stroke might not be suitable for all applications, specifically for applications using hard jaws and the chuck's adjustability feature to grip different diameters with the one set of jaws. This is due to the adjustment pitch of the chuck and jaw. For proper use in these applications, the actual jaw stroke should be about .050" longer or more than the adjustment pitch.

- 1= Chuck model size
- 2= Full chuck piston stroke- in.
- 3= Full jaw stroke using full chuck piston stroke- in.
- 4= Jaw adjustment pitch
- 5= Minimum cylinder stroke to provide jaw stroke of .050" longer than adjustment pitch.

1	2	3	4	5
170	.71"	.22"	.189"	.71"
210	.79	.25	.189	.76
225	.79	.25	.189	.76
265	1.10	.35	.216	.85
315	1.10	.36	.216	.85
400	1.18	.39	.216	.85
500	1.38	.45	.275	1.10
630	1.57	.50	.275	1.10

Chuck jaw stroke is directly proportional to piston stroke. The model UC 2 has no lost motion like some older models of wedge bar quick jaw change strokes. As an example, if you are installing a UC 2 size 265 on a cylinder with .95" of stroke, your actual jaw stroke should measure:

$$\frac{.350}{1.10} = \frac{X}{.95}$$

$$.95 \times .35 / 1.1 = .302" \text{ jaw stroke}$$

# ATS Systems Ultimate Chuck Installation and Operations Manual

( .302 - .216 = .086" longer than the adjustment pitch for comfortable use with adjustable hard jaws. )

**Record calculated stroke per jaw here= \_\_\_\_\_**

If your measured actual jaw stroke is shorter than the calculated jaw stroke, your drawtube length needs adjustment. See the two Notes: in section 3.1.2 above.

### **3.3 Use half-pitch base jaws when required.**

If your actual jaw stroke is less than .050" longer than the jaw adjustment pitch and you are using hard jaws and the adjustability feature of the chuck to grip different diameters, use half-pitch base jaws as required. Half-pitch base jaws look like standard base jaws except the position of the groove on the top of the base jaw that mates with the tongue on the bottom of the top-jaw is offset from the gear-rack by 1/2 the pitch of the gear-rack teeth. Use 1/2 pitch or standard base jaws as required to grip the diameter you need and allow each jaw to have at least .050" of residual travel after the part is gripped. Be sure your lathe's stroke control system is properly adjusted in case the chuck reaches the end of the jaw stroke without actually securely gripping the workpiece.

# ATS Systems Ultimate Chuck Installation and Operations Manual

## OPERATION:

### 4.1 Function and operation

Model UC2 and UC2B wedge bar chucks are actuated by rotary hydraulic or pneumatic cylinders. The axial drawbar pull and push forces are converted to radial jaw clamping force by tangential wedge bars positioned in the chuck body.

Adjusting or changing the base jaw/top jaw position must be done when the chuck is in the unclamped (cylinder full forward, jaws full outward) position. For safety reasons the base jaws and wedge bars are still interlocked when the chuck piston is in this position.

There is a cam bolt with hex socket in the chuck body for each jaw guideway that can be turned with the special chuck hex wrench only. Using a standard hex key wrench will damage the chuck due to the chuck's interlock safety mechanism. By turning the cam bolt, the teeth on the wedge bar are moved out of engagement with the teeth on the base jaw. In this position the base jaws can be adjusted inwards or outwards or they can be removed. It is not possible to remove the chuck key when it is rotated in this position.

**Caution:** Safe practice requires the operator to never remove his hand from the wrench when it is inserted into the chuck. This practice prevents the possibility of the lathe spindle being started and the wrench thrown out of the chuck



### ATTENTION

**The chuck piston should not be actuated as long as the chuck key is in one of the cam bolts of the chuck. To do so will cause damage to internal chuck components.**

### 4.2 Base Jaw Position

An arc with a zone marked "SAFE" below it (or a witness marking line) has been milled on the face of the chuck between the jaw guides (see figure 4.1).

This zone or witness line marks the maximum outward position of the base or monoblock jaw. The maximum outward jaw position has been reached when the chuck is in the jaw change position (chuck unclamped) and the edge of the base jaw or the one-piece monoblock jaw is inside (towards chuck centerline) of the arc or the witness line.



### WARNING

**It is essential to observe this jaw position to ensure that all teeth are interlocked for power transmission from the wedge bars to the base jaws. Never position jaws out past this limit.**

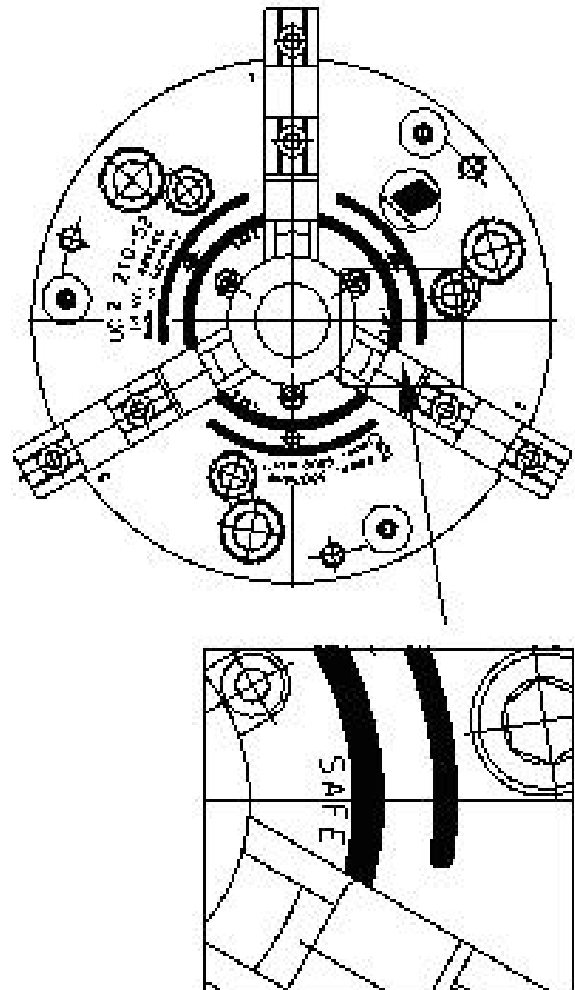

Fig 4.1

# ATS Systems Ultimate Chuck Installation and Operations Manual

## 4.3 Use half-pitch base jaws when required.

See this manual section 3.1.2

If your actual jaw stroke is less than .050" longer than the jaw adjustment pitch and you are using hard jaws and the adjustability feature of the chuck to grip different diameters, use half-pitch base jaws as required. Half-pitch base jaws look like standard base jaws except the position of the groove on the top of the base jaw that mates with the tongue on the bottom of the top-jaw is offset from the gear-rack by 1/2 the pitch of the gear-rack teeth. Use 1/2 pitch or standard base jaws as required to grip the diameter you need and allow each jaw to have at least .050" of residual travel after the part is gripped. Be sure your lathe's stroke control system is properly adjusted in case the chuck reaches the end of the jaw stroke without actually securely gripping the workpiece.

## 4.4 Bolting top jaws to base jaws

Torque top jaw to base jaw mounting bolts to the following specifications. Over tightening these bolts can distort the base jaw and cause them to bind in the jaw guideway. Under tightening could allow the top jaw to come loose from base jaw.

M8	18-24 ft-lb
M12	60-80 ft-lb
M16	140-180 ft-lb



### ATTENTION

**Never tighten jaw mounting bolts with a wrench extension (cheater bar) or by striking the wrench with a hammer! This can damage the bolts and lead to bolt failure.**

## 4.5 Top Jaw Concentricity

For best chucking concentricity, soft jaws must be bored in the chuck while gripping on a plug or ring with the same clamping force that will be used for the workpiece.

- When boring the jaws it is important that the boring ring or plug is clamped by the top jaws and not by the base jaws.

Keep base and top jaws screwed together for subsequent use without the need to rebore. Always tighten the jaw mounting bolts with the specified torque.

## 4.6 Estimating chuck grip force loss and approximate safe speed.

Proper determination of safe operating speed requires a dynamic grip force gage that allows the actual jaws in question to be run at operating speed. Start the test at a slow speed and increase speed until the minimum grip force to safely hold and machine the workpiece is reached. Only this empirical testing will guarantee accurate conclusions. To approximately determine the theoretical allowable speed for a particular set of jaws, one can weigh the jaws, measure their center of gravity by balancing them on a knife edge, and then make some calculations. These calculations assume the weights and measurements have been made accurately, that the chuck is well maintained, lubricated and working properly, that the starting static grip force is accurately known (cylinder size, pressure and resulting drawbar pull x chuck grip/pull ratio specification), and that the chuck is a high quality power chuck of modern design and construction. Since there are so many variables it would be dangerous to only make these theoretical calculations and then run the jaws at speed. But to give an estimate so that empirical testing can be planned, the following formulas can be used.

$F_{static}$  = lbs. of total starting grip force (all three or two jaws) with the chuck not rotating, using the draw bar pull (cylinder pressure) planned for the job.

$F_{@ speed}$  = lbs. of total grip force (all three or two jaws) you require remaining at operating RPM. You will need to determine this minimum grip force you require to safely hold the workpiece.

$W_{ju}$  = lbs., weight of one jaw unit = one master jaw plus one top jaw plus bolts (plus T-nuts plus master jaw for conventional chucks), or one monoblok jaw for wedge bar type quick jaw change chucks, such as the Ultimate Chuck. For conventional wedge hook or lever chucks, don't use the weight of just the top jaw or your theoretical allowable speed will be way too high. (You must

# ATS Systems Ultimate Chuck Installation and Operations Manual

disassemble and weigh a master jaw to add to the top jaw weight. When you do this you'll also want to determine the center of gravity and record these figures for future use.)

- r<sub>c</sub>** = in., radius dimension from centerline of chuck to the center of gravity of the jaw unit. For quick jaw change chucks where the entire jaw unit can be removed this can easily be done by balancing the jaw unit on a knife edge, marking the balance point and then inserting the jaw into the chuck to measure the distance from the chuck centerline to the balance point. For chucks with normal master jaws this radius is more difficult to determine.
- n** = RPM, speed of rotation
- n<sub>max</sub>** = RPM, theoretical approximate maximum allowable speed for the residual grip force you determined is required.
- a** = number of jaws (three or two)

Calculated maximum speed:

$$n_{max} = \sqrt{\frac{F_{static} - F_{@ speed}}{w_{ju} \times r_c \times a}} \times 188$$

Grip force loss (all three jaws, lbs.):

$$= \frac{w_{ju} \times a \times r_c \times n^2}{35,196}$$

### Example 1:

Ultimate Chuck size 210 (8") with full size monoblok soft jaw gripping a 2" diameter part. How fast can the chuck run and maintain 50% of it's static grip force of 19,000 lbs.?

Monoblok jaw weight = 1.5 lb./jaw = **w<sub>ju</sub>**  
Distance from chuck centerline to center of gravity of jaw = 2.5" = **r<sub>c</sub>**

$$n_{max} = \sqrt{\frac{19,000 - 9,500}{1.5 \times 2.5 \times 3}} \times 188 = 5465 \text{ rpm}$$

### Example 2:

Ultimate Chuck size 210 (8") with full size monoblok soft jaw gripping 2" diameter. What is the loss of grip force if the chuck is run at 6000 rpm?

Grip force loss, total all three jaws:

$$= \frac{1.5 \times 3 \times 2.5 \times 6000 \times 6000}{35,196} = 11,507 \text{ lbs. loss.}$$

or, if you started with a drawbar pull that yields 19,000 lbs. static you will have 19,000 minus 11,507 residual grip force remaining at 6000 RPM (assuming the weights, measurements and all other assumptions are accurate.) or about 7,493 lbs = 39% of the initial 19,000 lbs.

### Example 3:

Ultimate Chuck size 315 (12") with a full monoblok soft jaw gripping a 3.5" diameter. How fast can you run and maintain 50% of an initial 30,000 lbs. of grip force?

Jaw weighs 5.4 lbs., **r<sub>c</sub>** = 4.075"

$$n_{max} = \sqrt{\frac{30,000 - 15,000}{5.4 \times 4.075 \times 3}} \times 188 = 2833 \text{ rpm}$$

### Example 4:

Ultimate Chuck size 500 (20"), "pie" jaws weighing 65 lb. each. Static grip at 20,000 lb. to prevent crushing the thin walled workpiece. What's the max RPM for 10,000 lb. remaining?

$$n_{max} = \sqrt{\frac{20,000 - 10,000}{65 \times 7 \times 3}} \times 188 = 509 \text{ rpm}$$

Note: At 720 rpm the calculated grip force has dropped to zero! Any small error in measurements can have major consequences. Hence the need for actual testing with a dynamic grip force gage.

# ATS Systems Ultimate Chuck Installation and Operations Manual

## **4.7 Periodically check your jaw stroke**

See section 3.1.2. Especially if you are using hard jaws and the adjustability feature of the Ultimate Chuck, you should regularly check your jaw stroke and compare your actual stroke to the stroke you calculated in 3.1.2. If you have lost any jaw stroke, check your drawtube adjustment.

## **4.8 Increase hydraulic pressure 30% to achieve same static grip force as wedge hook chucks.**

In most applications, the challenge for a chuck is to maintain grip force and hold a workpiece at high speed. At high speed, the Ultimate Chuck will maintain a much higher percentage of the original static grip force (static = without the chuck rotating) than a simple wedge-hook chuck. For this reason, you can start at a lower static grip force and hold on to the part at high speed. This is especially valuable for fragile parts. At the high rated speed of the chuck, using standard ATS Systems hard jaws gripping a diameter equal to the through hole of the chuck, you will maintain over 65% of the static grip force.

The Ultimate Chuck will generate higher grip forces than simple wedge-hook chucks and will consume much higher drawbar pull. But to generate the same static grip force as a wedge-hook chuck you need to increase the drawbar pull (increase hydraulic pressure) 30%. If you have low speed applications that require high grip force (such as very large twist drills) and you have recorded hydraulic pressures for the cylinder you are using, increase this pressure 30% to get the same grip force with your Ultimate Chuck as you did with the simple wedge-hook chuck.

# ATS Systems Ultimate Chuck Installation and Operations Manual

## MAINTENANCE:

### 5.1 Disassembly and assembly of the chuck



#### WARNING

**Never attempt to disassemble the chuck when it is installed on the lathe. Always remove the chuck from the lathe before starting any disassembly.**

See 6.1 in the OTHER INFO in section of this manual for parts identification.

- Remove base jaws. Position chuck on edge or suspend from a crane.
- Loosen the screws (26) several threads and strike the screw heads lightly with a rubber mallet. By doing this, the backplate (2) will come loose from the chuck body. Remove screws (26) and remove the backplate (mark the position of the chuck backplate to the chuck body).
- Lay chuck on its face.
- Remove three pins (14) with springs and balls (43&38).
- Remove three Cam Bolts (11) by rotating them to release ball (39) and pulling out.
- Pull straight up on actuator (3) and lift actuator along with three wedge bar assemblies (6). Remove wedge bar assemblies, remove actuator.
- Note that wedge bars are numbered 1,2,3 and must go back in the wedge bar pockets for the jaw guideways with the same number 1,2,3.
- To disassemble wedge bar assemblies, pull up on Rack (8) and remove. Keep Rack (8) with the wedge bar it came out of and put back into the same wedge bar to avoid any change that would require previously bored soft jaws to be rebored. On smaller chucks, (9) can be pulled directly out of the bottom of the wedge bar. Larger sizes have a screw in the wedge bar in the area of (17) to remove.
- Remove any remaining parts, but we recommend not removing the Guide Bushing (15). Clean all

parts and check for damage. Before reassembling, lightly grease with ATS K05 lubricant.

⇒ *Use only original spare parts from ATS Systems when replacing damaged components. Phone ATS Systems at 1-800 423-4651*

Reassemble the chuck in the reverse order. Be sure to get the correct numbered wedge bar back into the correct pocket. Read Lubrication section 5.2.1 below before putting Backplate on..

### 5.2 Lubrication

#### 5.2.1 Lubricating the chuck body. (See 5.2.2 for jaw guideway lubrication.)

The reliability of the chuck can only be guaranteed if the maintenance requirements in these operating instructions are followed exactly. In particular, attention must be paid to:

- Lubrication: Only ATS K05 grease should be used. (Unsuitable lubricants can reduce the clamping force by more than 50%). The chuck should be greased each **24** hours of operation under normal conditions. See table in 5.2.3.
- All surfaces that require lubrication must be reached. (The close fits of mating parts require a high injecting pressure. For this reason a high pressure grease gun should be used). **Important:** Grease must be injected into the three fittings on the face of the chuck when the chuck jaws are fully opened (jaws outward from centerline). **It is only in this position that lubrication will properly reach the internal components of the chuck.**
- To ensure good grease distribution, inject one shot of grease into each of the three grease fittings, actuate the chuck full stroke several times, and then inject a second shot of grease into each of the three fittings. Check the clamping force with a grip force gauge.
- After each **50** clamping strokes it is advisable to actuate the chuck several times without gripping a workpiece so that the chuck is stroked to its extreme limits. When this is done, lubricant that has been displaced is returned to the pressure surfaces and the clamping force is retained for a longer period of time without re-lubrication.

# ATS Systems Ultimate Chuck Installation and Operations Manual

- Depending on the application and the workpiece materials being machined, the chuck will periodically need to be disassembled and cleaned. After cleaning, all internal parts must be coated with a film of KO5 grease, and the chuck body cavities at either end of the wedge bars filled 50% with KO5 grease. Each time the chuck is actuated and the wedge bars stroke, this “reservoir” of grease is pumped back through ports in the wedge bar to lubricate critical surfaces.
- It is recommended that the clamping force be checked using a grip force gauge before beginning a new production batch and between maintenance checks. Only regular checks can guarantee safety.

Lubricate and test the chuck at the following intervals:

Operating Hours	Amount of Contaminants
20-30	Normal amount
8	High amount
1000-1500	Total disassembly and cleaning of chuck

The base jaws must move easily and smoothly at the lowest possible operating pressure (cylinder).

## 5.2.2 Lubricating jaw guideways

When changing the base jaw or one-piece jaws, the teeth and jaw guideways must be cleaned and lightly greased with ATS K05 grease.

Ultimate Chucks were designed primarily for JIT applications with frequent jaw changeover. No grease fitting ports lubricate the jaw guideways. Whenever jaws are changed, inspect the chuck guideways for cleanliness and put a film of grease on the sliding surfaces of the master base jaws before inserting them into the chuck. For high volume production applications when jaws aren't changed frequently, the jaws should be removed once per shift (depending on machining cycle time), cleaned and re-lubricated. Optional master base jaws with grease fittings are available as special order.

## 5.2.3 Lubrication and maintenance frequency

Depending on operating conditions, check the function and the clamping force after the length of operation specified in the table below. Clamping force must be measured with a grip force gauge.



### WARNING

**If grip force has dropped, or if base jaws and piston can no longer be moved freely, then it is necessary to immediately take the chuck out of operation, disassemble, inspect, clean, repair as required and re-lubricate it.**

## 5.3 Ordering Spare Parts

⇒ *Use only original spare parts from ATS Systems when replacing damaged components.*

**Phone ATS Systems at 1-800 423-4651 or purchase online at [www.ats-s.com](http://www.ats-s.com)**

See drawing 6.1 in the OTHER INFO section of this manual for spare parts identification. Order spare parts by specifying the chuck model and serial number, and the part item number and description.



## UC2 - ULTIMATE CHUCK GENERAL PARTS LIST

Item	Description	Sold As
1	Chuck Body	NSS
2	Backplate	Each
3	Actuator	Each
4	Drawtube Adapter	Each
5	Retaining Ring - Drawtube	Each
6	Wedge Bar Kit (Inc. 7, 8, 9, 10, 12, 17, 18, 30, 31, 42, 44, 48)	Set of 1
7*	Wedge Bar	Kit
8*	Rack, Wedge Bar	Kit
9*	Cam, Wedge Bar	Kit
10	Pin, Jaw Pre-Position	Each
11	Cam Bolt	Each
12	Cam Pin	Each
14	Pin, Cam Bolt	Each
15	Guide Bushing	Each
16	Pin Keeper	Each
17	Pin, Cam	Each
18	Cap	Each
21	Base Jaw	Set of 3
26	Screw	Each
27	Screw	Each
29	Screw	Each
30	Screw, Special	Each
31	Pin	Each
34	Grease Fitting	Each
38	Ball, Cam Pin	Each
39	Ball, Cam Bolt	Each
42	Spring, Rack	Each
43	Spring, Cam Bolt	Each
44	Spring, Cam	Each
47	Wrench, Jaw Change	Each
48	Effector, Cam Pin	Each
51	Wrench, Drawtube Adapter	Each
60	Wrench, Retaining Ring	Each

\*Note - Sold with Kit #6 only.

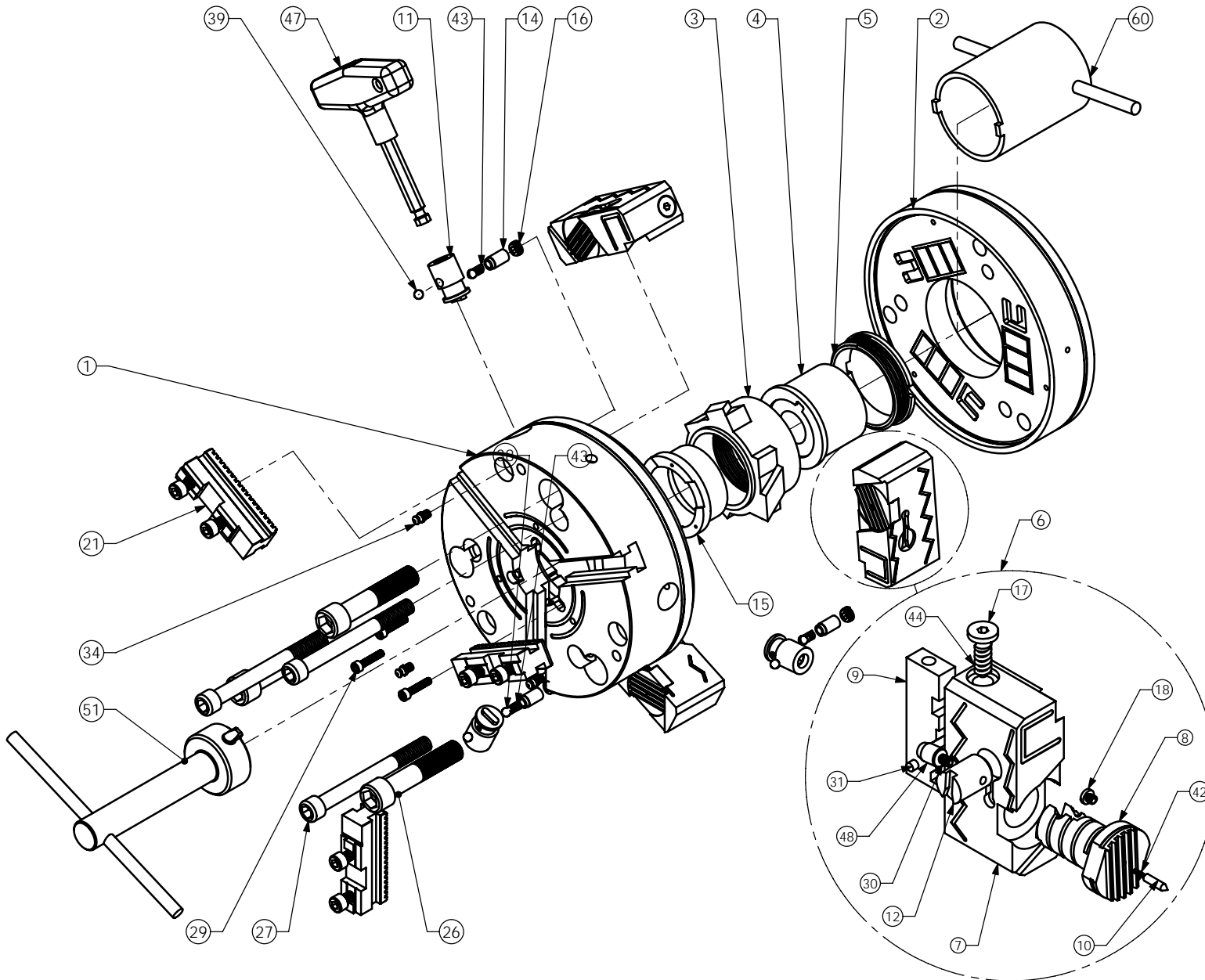

ATS Systems (Formerly SMW Systems)  
Ultimate Chuck (UC2) Spare Parts List

Model	Size	Thru-Hole	Mount	Ref #	ATS Part #	PART DESCRIPTION
UC2	170	45	3Z		2403-0110	UC2-170-45 3Z Chuck assembly
UC2	170	45	A5		2403-0120	UC2-170-45 A-5 Chuck assembly
UC2	170	45	A6		2403-0130	UC2-170-45 A-6 Chuck assembly
UC2	170	45	All	1	2400-0100	Chuck body - UC2 170-45
UC2	170	45	3Z	2a	2400-1100	Backplate, UC2 170-45 3Z
UC2	170	45	A5	2b	2400-1110	Backplate, UC2 170-45 3A5
UC2	170	45	A6	2c	2400-1120	Backplate, UC2 170-45 3A6
UC2	170	45	All	3	2400-0120	Actuator UC2 170-45
UC2	170	45	All	4	2400-0040	Blank drawtube adapter UC2 170-45
UC2	170	45	All	5	2400-0300	Retaining ring drawtube adapter
UC2	170	45	All	20	2400-0600	Wedge bar assembly UC2 170-45
UC2	170	45	All	7	2400-0140	Wedge bar UC2 170-45
UC2	170	45	All	8	2400-0160	Rack, wedge bar UC2 170-45
UC2	170	45	All	9	2400-0180	Cam, wedge bar rack UC2 170-45
UC2	170	45	All	10	2400-0200	Pin, jaw pre-position UC2 170-45
UC2	170	45	All	11	2400-0220	Cam bolt UC2 170-45
UC2	170	45	All	12	2400-0240	Cam pin UC2 170-45
UC2	170	45	All	14	2400-0260	Pin, Keeper UC2 170-45 (OLD)
UC2	170	45	All	14	2400-0261	Pin, Keeper UC2 170-45 (NEW)
UC2	170	45	All	16	n/a	Not Required
UC2	170	45	All	15	2400-0280	Guide bushing UC2 170-45
UC2	170	45	All	17	2400-0320	Pin UC2 170-45
UC2	170	45	All	18	2400-0340	Cap, Spring UC2 170-45
UC2	170	45	All	21	1192-2210	Base jaw with cap screws
UC2	170	45	All	22	80-0158	Socket head cap screw M8X20
UC2	170	45	3Z	26a	80-0739	Socket head cap screw M12X70
UC2	170	45	A5	26b	80-0428	Socket head cap screw M12X90
UC2	170	45	A6	26c	80-0494	Socket head cap screw M12X110
UC2	170	45	3Z	27a	80-1033	Socket head cap screw M10X95
UC2	170	45	A5	27b	80-1006	Socket head cap screw M10X105
UC2	170	45	A6	27c		Socket head cap screw M10X70
UC2	170	45	All	29	80-0877	Socket head cap screw M4X20
UC2	170	45	All	30	80-0956	Screw special UC2 170-45
UC2	170	45	All	31	2400-0360	Pin
UC2	170	45	All	34	2200-7019	Fitting grease M6X1
UC2	170	45	All	36		Plug
UC2	170	45	All	38	1142-2626	Ball steel 6.0 mm
UC2	170	45	All	39	1142-2615	Ball steel 7.0 mm
UC2	170	45	All	40		Plug, blance correction
UC2	170	45	All	42	2400-0440	Spring
UC2	170	45	All	43	2400-0456	Spring
UC2	170	45	All	44	2400-0460	Spring

ATS Systems (Formerly SMW Systems)  
Ultimate Chuck (UC2) Spare Parts List

UC2	170	45	All	47	2400-0386	Wrench, jaw change 170/315
UC2	170	45	All	48	2400-0390	Effector, cam pin 170/315
UC2	170	45	All	51	2400-0400	Wrench, drawtube adjusting
UC2	170	45	All	60	2400-0420	Wrench, retaining ring
UC2	210	52	3Z		2403-0210	UC2-210-52 3Z Chuck assembly
UC2	210	52	A6		2403-0220	UC2-210-52 A-6 Chuck assembly
UC2	210	52	A8		2403-0230	UC2-210-52 A-8 Chuck assembly
UC2	210	52	All	1	2400-0102	Chuck body - UC2 210-52
UC2	210	52	3Z	2a	2400-1200	Backplate, UC2 210-52 3Z
UC2	210	52	A6	2b	2400-1210	Backplate, UC2 210-52 3A6
UC2	210	52	A8	2c	2400-1220	Backplate, UC2 210-52 3A8
UC2	210	52	All	3	2400-0122	Actuator UC2 210-52
UC2	210	52	All	4	2400-0042	Blank drawtube adapter UC2 210-52
UC2	210	52	All	5	2400-0302	Retaining ring drawtube adapter
UC2	210	52	All	20	2400-0602	Wedge bar assembly UC2 210/225
UC2	210	52	All	7	2400-0142	Wedge bar UC2 210/225
UC2	210	52	All	8	2400-0162	Rack, wedge bar UC2 210/225
UC2	210	52	All	9	2400-0182	Cam, wedge bar rack UC2 210/225
UC2	210	52	All	10	2400-0202	Pin, jaw pre-position UC2 210/225
UC2	210	52	All	11	2400-0222	Cam bolt UC2 210/225
UC2	210	52	All	12	2400-0242	Cam pin UC2 210/225
UC2	210	52	All	14	2400-0262	Pin, keeper UC2 210/225 (OLD)
UC2	210	52	All	14	2400-0263	Pin, keeper UC2 210/225 (NEW)
UC2	210	52	a	16	n/a	Not Required
UC2	210	52	All	15	2400-0282	Guide bushing UC2 210-52
UC2	210	52	All	17	2400-0322	Pin UC2 210/315
UC2	210	52	All	18	2400-0342	Locking screw UC2 210/400
UC2	210	52	All	21	1192-2220	Base jaw with cap screws
UC2	210	52	All	22	80-0158	Socket head cap screw M8X20
UC2	210	52	3Z	26a	80-0656	Socket head cap screw M16X80
UC2	210	52	A6	26b	80-0656	Socket head cap screw M16X80
UC2	210	52	A8	26c	80-0305	Socket head cap screw M16X120
UC2	210	52	3Z	27a	80-1011	Socket head cap screw M12X105
UC2	210	52	A6	27b	80-0252	Socket head cap screw M12X120
UC2	210	52	A8	27c	80-0657	Socket head cap screw M12X80
UC2	210	52	All	29	80-0685	Socket head cap screw M5X25
UC2	210	52	All	30	80-0956	Screw special UC2 210-52
UC2	210	52	All	31	2400-0362	Pin
UC2	210	52	All	34	2200-7019	Fitting grease M6X1
UC2	210	52	All	36		Plug
UC2	210	52	All	38	1142-2626	Ball steel 6.0 mm
UC2	210	52	All	39	1142-2615	Ball steel 7.0 mm
UC2	210	52	All	40		Plug, blance correction
UC2	210	52	All	42	2400-0442	Spring

ATS Systems (Formerly SMW Systems)  
Ultimate Chuck (UC2) Spare Parts List

UC2	210	52	All	43	2400-0456	Spring
UC2	210	52	All	44	2400-0462	Spring
UC2	210	52	All	47	2400-0386	Wrench, jaw change 170/315
UC2	210	52	All	48	2400-0390	Effector, cam pin 170/315
UC2	210	52	All	51	2400-0402	Wrench, drawtube adjusting
UC2	210	52	All	60	2400-0422	Wrench, retaining ring
UC2	225	68	3Z		2403-0310	UC2-225-68 3Z Chuck assembly
UC2	225	68	A6		2403-0320	UC2-225-68 A-6 Chuck assembly
UC2	225	68	A8		2403-0330	UC2-225-68 A-8 Chuck assembly
UC2	225	68	All	1	2400-0104	Chuck body - UC2 225-68
UC2	225	68	3Z	2a	2400-1300	Backplate, UC2 225-68 3Z
UC2	225	68	A6	2b	2400-1310	Backplate, UC2 225-68 3A6
UC2	225	68	A8	2c	2400-1320	Backplate, UC2 225-68 3A8
UC2	225	68	All	3	2400-0124	Actuator UC2 225-68
UC2	225	68	All	4	2400-0044	Blank drawtube adapter UC2 210-52
UC2	225	68	All	5	2400-0304	Retaining ring drawtube adapter
UC2	225	68	All	20	2400-0602	Wedge bar assembly UC2 210/225
UC2	225	68	All	7	2400-0142	Wedge bar UC2 210/225
UC2	225	68	All	8	2400-0162	Rack, wedge bar UC2 210/225
UC2	225	68	All	9	2400-0182	Cam, wedge bar rack UC2 210/225
UC2	225	68	All	10	2400-0202	Pin, jaw pre-position UC2 210/225
UC2	225	68	All	11	2400-0222	Cam bolt UC2 210/225
UC2	225	68	All	12	2400-0242	Cam pin UC2 210/225
UC2	225	68	All	14	2400-0262	Pin, keeper UC2 210/225 (OLD)
UC2	225	68	All	14	2400-0263	Pin, keeper UC2 210/225 (NEW)
UC2	225	68	All	16	n/a	Not Required
UC2	225	68	All	15	2400-0284	Guide bushing UC2 225-68
UC2	225	68	All	17	2400-0322	Pin UC2 210/315
UC2	225	68	All	18	2400-0342	Cap, Spring UC2 210/400
UC2	225	68	All	21	1192-2220	Base jaw with cap screws
UC2	225	68	All	22	80-0158	Socket head cap screw M8X20
UC2	225	68	3Z	26a	80-0656	Socket head cap screw M16X80
UC2	225	68	A6	26b	80-0656	Socket head cap screw M16X80
UC2	225	68	A8	26c	80-0305	Socket head cap screw M16X120
UC2	225	68	3Z	27a	80-1011	Socket head cap screw M12X105
UC2	225	68	A6	27b	80-0252	Socket head cap screw M12X120
UC2	225	68	A8	27c	80-0657	Socket head cap screw M12X80
UC2	225	68	All	29	80-0685	Socket head cap screw M5X25
UC2	225	68	All	30	80-0956	Screw special UC2 210-52
UC2	225	68	All	31	2400-0362	Pin
UC2	225	68	All	34	2200-7019	Fitting grease M6X1
UC2	225	68	All	36		Plug
UC2	225	68	All	38	1142-2626	Ball steel 6.0 mm
UC2	225	68	All	39	1142-2615	Ball steel 7.0 mm

ATS Systems (Formerly SMW Systems)  
Ultimate Chuck (UC2) Spare Parts List

UC2	225	68	All	40		Plug, blance correction
UC2	225	68	All	42	2400-0442	Spring
UC2	225	68	All	43	2400-0456	Spring
UC2	225	68	All	44	2400-0462	Spring
UC2	225	68	All	47	2400-0386	Wrench, jaw change 170/315
UC2	225	68	All	48	2400-0390	Effector, cam pin 170/315
UC2	225	68	All	51	2400-0404	Wrench, drawtube adjusting
UC2	225	68	All	60	2400-0424	Wrench, retaining ring
UC2	265	77	3Z		2403-0410	UC2-265-77 3Z Chuck assembly
UC2	265	77	A6		2403-0420	UC2-265-77 A-6 Chuck assembly
UC2	265	77	A8		2403-0430	UC2-265-77 A-8 Chuck assembly
UC2	265	77	All	1	2400-0106	Chuck body - UC2 265-77
UC2	265	77	3Z	2a	2400-1400	Backplate, UC2 265-77 3Z
UC2	265	77	A6	2b	2400-1410	Backplate, UC2 265-77 3A6
UC2	265	77	A8	2c	2400-1420	Backplate, UC2 265-77 3A8
UC2	265	77	All	3	2400-0126	Actuator UC2 265-77
UC2	265	77	All	4	2400-0046	Blank drawtube adapter UC2 265-77
UC2	265	77	All	5	2400-0306	Retaining ring drawtube adapter
UC2	265	77	All	20	2400-0604	Wedge bar assembly UC2 265-77
UC2	265	77	All	7	2400-0146	Wedge bar UC2 265-77
UC2	265	77	All	8	2400-0166	Rack, wedge bar UC2 265-77
UC2	265	77	All	9	2400-0186	Cam, wedge bar rack UC2 265-77
UC2	265	77	All	10	2400-0206	Pin, jaw pre-position UC2 265-77
UC2	265	77	All	11	2400-0226	Cam bolt UC2 265-77
UC2	265	77	All	12	2400-0246	Cam pin UC2 265-77
UC2	265	77	All	14	2400-0265	Pin, keeper UC2 265/315 (OLD)
UC2	265	77	All	14/16	2400-0267	Pin, keeper UC2 265 (NEW)
UC2	265	77	All	14/16	2400-0472	Plug for keep pin
UC2	265	77	All	15	2400-0286	Guide bushing UC2 265-77
UC2	265	77	All	17	2400-0322	Pin UC2 210/315
UC2	265	77	All	18	2400-0342	Cap, Spring UC2 210/400
UC2	265	77	All	21	1192-2225	Base jaw with cap screws
UC2	265	77	All	22	80-0168	Socket head cap screw M12X30
UC2	265	77	3Z	26a	80-0885	Socket head cap screw M16X90
UC2	265	77	A6	26b	80-0885	Socket head cap screw M16X90
UC2	265	77	A8	26c	80-0883	Socket head cap screw M16X140
UC2	265	77	3Z	27a		Socket head cap screw M12X135
UC2	265	77	A6	27b	80-1038	Socket head cap screw M12X140
UC2	265	77	A8	27c	80-0428	Socket head cap screw M12X90
UC2	265	77	All	29		Socket head cap screw M5X30
UC2	265	77	All	30	80-0956	Screw special UC2 265-77
UC2	265	77	All	31	2400-0366	Pin
UC2	265	77	All	34	2200-7019	Fitting grease M6X1
UC2	265	77	All	36		Plug

ATS Systems (Formerly SMW Systems)  
Ultimate Chuck (UC2) Spare Parts List

UC2	265	77	All	38	1142-2626	Ball steel 6.0 mm
UC2	265	77	All	39	1142-2615	Ball steel 7.0 mm
UC2	265	77	All	40		Plug, blance correction
UC2	265	77	All	42	2400-0442	Spring
UC2	265	77	All	43	2400-0456	Spring
UC2	265	77	All	44	2400-0462	Spring
UC2	265	77	All	47	2400-0386	Wrench, jaw change 170/315
UC2	265	77	All	48	2400-0390	Effector, cam pin 170/315
UC2	265	77	All	51	2400-0406	Wrench, drawtube adjusting
UC2	265	77	All	60	2400-0426	Wrench, retaining ring
UC2	315	91	3Z		2403-0510	UC2-315-91 3Z Chuck assembly
UC2	315	91	A8		2403-0520	UC2-315-91 A-8 Chuck assembly
UC2	315	91	A11		2403-0530	UC2-315-91 A-11 Chuck assembly
UC2	315	91	ALL	1	2400-0108	Chuck body - UC2 315-91
UC2	315	91	3Z	2a	2400-1500	Backplate, UC2 315-91 3Z
UC2	315	91	A8	2b	2400-1510	Backplate, UC2 315-91 3A8
UC2	315	91	A11	2c	2400-1520	Backplate, UC2 315-91 3A11
UC2	315	91	ALL	3	2400-0128	Actuator UC2 315-91
UC2	315	91	ALL	4	2400-0048	Blank drawtube adapter UC2 315-91
UC2	315	91	ALL	5	2400-0308	Retaining ring drawtube adapter
UC2	315	91	ALL	20	2400-0606	Wedge bar assembly UC2 315-91
UC2	315	91	ALL	7	2400-0148	Wedge bar UC2 315-91
UC2	315	91	ALL	8	2400-0168	Rack, wedge bar UC2 315-91
UC2	315	91	ALL	9	2400-0188	Cam, wedge bar rack UC2 315-91
UC2	315	91	ALL	10	2400-0208	Pin, jaw pre-position UC2 315-91
UC2	315	91	ALL	11	2400-0228	Cam bolt UC2 315-91
UC2	315	91	ALL	12	2400-0246	Cam pin UC2 265/315
UC2	315	91	ALL	14	2400-0265	Pin, keeper UC2 265/315 (Old)
UC2	315	91	ALL	14/16	2400-0269	Pin, keeper UC2 315 (NEW)
UC2	315	91	ALL	14/16	2400-0472	Plug for keep pin
UC2	315	91	ALL	15	2400-0288	Guide bushing UC2 315-91
UC2	315	91	ALL	17	2400-0322	Pin UC2 210/315
UC2	315	91	ALL	18	2400-0342	Cap, Spring UC2 210/400
UC2	315	91	ALL	21	1192-2231	Base jaw with cap screws
UC2	315	91	ALL	22	80-0168	Socket head cap screw M12X30
UC2	315	91	3Z	26a		Socket head cap screw M20x105
UC2	315	91	A8	26b		Socket head cap screw M20x105
UC2	315	91	A11	26c	80-0615	Socket head cap screw M20X150
UC2	315	91	3Z	27a	80-0508	Socket head cap screw M16X135
UC2	315	91	A8	27b	80-0621	Socket head cap screw M16x155
UC2	315	91	A11	27c		Socket head cap screw M16X105
UC2	315	91	ALL	29	80-0156	Socket head cap screw M6X30
UC2	315	91	ALL	30	80-0956	Screw special UC2 315-91
UC2	315	91	ALL	31	2400-0366	Pin

ATS Systems (Formerly SMW Systems)  
Ultimate Chuck (UC2) Spare Parts List

UC2	315	91	ALL	34	2200-7019	Fitting grease M6X1
UC2	315	91	ALL	36		Plug
UC2	315	91	ALL	38	1142-2626	Ball steel 6.0 mm
UC2	315	91	ALL	39	1142-2615	Ball steel 7.0 mm
UC2	315	91	ALL	40		Plug, blance correction
UC2	315	91	ALL	42	2400-0446	Spring
UC2	315	91	ALL	43	2400-0456	Spring
UC2	315	91	ALL	44	2400-0462	Spring
UC2	315	91	ALL	47	2400-0386	Wrench, jaw change 170/315
UC2	315	91	ALL	48	2400-0390	Effector, cam pin 170/315
UC2	315	91	ALL	51	2400-0408	Wrench, drawtube adjusting
UC2	315	91	ALL	60	2400-0428	Wrench, retaining ring
UC2	315	104	3Z		2403-0546	UC2-315-104 3Z Chuck assembly
UC2	315	104	A8		2403-0540	UC2-315-104 A-8 Chuck assembly
UC2	315	104	A11		2403-0542	UC2-315-104 A-11 Chuck assembly
UC2	315	104	ALL	1	2400-0109	Chuck body - UC2 315-104
UC2	315	104	3Z	2a	2400-1504	Backplate, UC2 315-104 3Z
UC2	315	104	A8	2b	2400-1514	Backplate, UC2 315-104 3A8
UC2	315	104	A11	2c	2400-1530	Backplate, UC2 315-104 3A11
UC2	315	104	ALL	3	2400-0129	Actuator UC2 315-104
UC2	315	104	ALL	4	2400-0049	Blank drawtube adapter UC2 315-104
UC2	315	104	ALL	5	2400-0309	Retaining ring drawtube adapter
UC2	315	104	ALL	20	2400-0606	Wedge bar assembly UC2 315-91&104
UC2	315	104	ALL	7	2400-0148	Wedge bar UC2 315-91
UC2	315	104	ALL	8	2400-0168	Rack, wedge bar UC2 315-91&104
UC2	315	104	ALL	9	2400-0188	Cam, wedge bar rack UC2 315-91&104
UC2	315	104	ALL	10	2400-0208	Pin, jaw pre-position UC2 315-91&104
UC2	315	104	ALL	11	2400-0229	Cam bolt UC2 315-104
UC2	315	104	ALL	12	2400-0246	Cam pin UC2 265/315
UC2	315	104	ALL	14	2400-0265	Pin, keeper UC2 265/315 (Old)
UC2	315	104	ALL	14/16	2400-0267	Pin, keeper UC2 315 (New)
UC2	315	104	ALL	14/16	2400-0472	Plug for keep pin
UC2	315	104	ALL	15	2400-0289	Guide bushing UC2 315-104
UC2	315	104	ALL	17	2400-0322	Pin UC2 210/315
UC2	315	104	ALL	18	2400-0342	Cap, Spring UC2 210/400
UC2	315	104	ALL	21	1192-2231	Base jaw with cap screws
UC2	315	104	ALL	22	80-0168	Socket head cap screw M12X30
UC2	315	104	3Z	26a		Socket head cap screw M20x105
UC2	315	104	A8	26b		Socket head cap screw M20x105
UC2	315	104	A11	26c	80-0615	Socket head cap screw M20X150
UC2	315	104	3Z	27a	80-0508	Socket head cap screw M16X135
UC2	315	104	A8	27b	80-0621	Socket head cap screw M16x155
UC2	315	104	A11	27c		Socket head cap screw M16X105
UC2	315	104	ALL	29	80-0156	Socket head cap screw M6X30

ATS Systems (Formerly SMW Systems)  
Ultimate Chuck (UC2) Spare Parts List

UC2	315	104	ALL	30	80-0956	Screw special UC2 315-91&104
UC2	315	104	ALL	31	2400-0366	Pin
UC2	315	104	ALL	34	2200-7019	Fitting grease M6X1
UC2	315	104	ALL	36		Plug
UC2	315	104	ALL	38	1142-2626	Ball steel 6.0 mm
UC2	315	104	ALL	39	1142-2615	Ball steel 7.0 mm
UC2	315	104	ALL	40		Plug, blance correction
UC2	315	104	ALL	42	2400-0446	Spring
UC2	315	104	ALL	43	2400-0456	Spring
UC2	315	104	ALL	44	2400-0462	Spring
UC2	315	104	ALL	47	2400-0386	Wrench, jaw change 170/315
UC2	315	104	ALL	48	2400-0390	Effector, cam pin 170/315
UC2	315	104	ALL	51	2400-0409	Wrench, drawtube adjusting
UC2	315	104	ALL	60	2400-0429	Wrench, retaining ring
UC2	400	128	3Z		2403-0610	UC2-400-128 3Z-300 Chuck assembly
UC2	400	128	3Z		2403-0615	UC2-400-128 3Z-380 Chuck assembly
UC2	400	128	A11		2403-0620	UC2-400-128 A-11 Chuck assembly
UC2	400	128	A15		3403-0630	UC2-400-128 A-15 Chuck assembly
UC2	400	128	ALL	1	2400-0108	Chuck body - UC2 400-128
UC2	400	128	3Z	2a	2400-1600	Backplate, UC2 400-128 3Z-300
UC2	400	128	3Z	2b	2400-1610	Backplate, UC2 400-128 3Z-380
UC2	400	128	A11	2c	2400-1620	Backplate, UC2 400-128 3A11
UC2	400	128	A15	2d	2400-1630	Backplate, UC2 400-128 3A15
UC2	400	128	ALL	3	2400-0130	Actuator UC2 400-128
UC2	400	128	ALL	4	2400-0050	Blank drawtube adapter UC2 400-128
UC2	400	128	ALL	5	2400-0310	Retaining ring drawtube adapter
UC2	400	128	ALL	20	2400-0608	Wedge bar assembly UC2 400-128
UC2	400	128	ALL	7	2400-0150	Wedge bar UC2 400-128
UC2	400	128	ALL	8	2400-0170	Rack, wedge bar UC2 400-128
UC2	400	128	ALL	9	2400-0190	Cam, wedge bar rack UC2 400-128
UC2	400	128	ALL	10	2400-0210	Pin, jaw pre-position UC2 400-128
UC2	400	128	ALL	11	2400-0230	Cam bolt UC2 400-128
UC2	400	128	ALL	12	2400-0250	Cam pin UC2 400-128
UC2	400	128	ALL	14	2400-0270	Pin, keeper UC2 400/500 (OLD)
UC2	400	128	ALL	14/16	2400-0271	Pin, keeper UC2 400 (NEW)
UC2	400	128	ALL	14/16	2400-0472	Plug for keep pin
UC2	400	128	ALL	15	2400-0290	Guide bushing UC2 400-128
UC2	400	128	ALL	17	2400-0330	Pin UC2 400/500
UC2	400	128	ALL	18	2400-0342	Cap, Spring UC2 210/400
UC2	400	128	ALL	21	1192-2240	Base jaw with cap screws
UC2	400	128	ALL	22	80-0387	Socket head cap screw M12X25
UC2	400	128	3Z	26a	80-0503	Socket head cap screw M20x140
UC2	400	128	3Z	26b		Socket head cap screw M24x150
UC2	400	128	A11	26c	80-0421	Socket head cap screw M20x160

ATS Systems (Formerly SMW Systems)  
Ultimate Chuck (UC2) Spare Parts List

UC2	400	128	A15	26d	80-0447	Socket head cap screw M20x110
UC2	400	128	3Z	27a	80-1091	Socket head cap screw M24x120
UC2	400	128	3Z	27b	80-0447	Socket head cap screw M20x110
UC2	400	128	A11	27c		Socket head cap screw M24x130
UC2	400	128	A15	27d		Socket head cap screw M24x160
UC2	400	128	ALL	29	80-0156	Socket head cap screw M6X30
UC2	400	128	ALL	30	80-1151	Screw special UC2 400-128
UC2	400	128	ALL	31	2400-0370	Pin
UC2	400	128	ALL	34	2200-7019	Fitting grease M6X1
UC2	400	128	ALL	36		Plug
UC2	400	128	ALL	38	1142-2626	Ball steel 6.0 mm
UC2	400	128	ALL	39	1142-2615	Ball steel 7.0 mm
UC2	400	128	ALL	40		Plug, blance correction
UC2	400	128	ALL	42	2400-0446	Spring
UC2	400	128	ALL	43	2400-0456	Spring
UC2	400	128	ALL	44	2400-0466	Spring
UC2	400	128	ALL	47	2400-0386	Wrench, jaw change 400/630
UC2	400	128	ALL	48	2400-0392	Effector, cam pin 400/500
UC2	400	128	ALL	51	2400-0410	Wrench, drawtube adjusting
UC2	400	128	ALL	60	2400-0430	Wrench, retaining ring
UC2	500	155	3Z		2403-0710	UC2-500-155 3Z 380 Chuck assembly
UC2	500	155	A11		2403-0720	UC2-500-155 A-11 Chuck assembly
UC2	500	155	A15		2403-0730	UC2-500-155 A-15 Chuck assembly
UC2	500	155	ALL	1	2400-0112	Chuck body - UC2 500-155
UC2	500	155	3Z	2a	2400-1700	Backplate, UC2 500-155 3Z
UC2	500	155	A11	2b	2400-1710	Backplate, UC2 500-155 A11
UC2	500	155	A15	2c	2400-1720	Backplate, UC2 500-155 A15
UC2	500	155	ALL	3	2400-0132	Actuator UC2 500-155
UC2	500	155	ALL	4	2400-0052	Blank drawtube adapter UC2 500-155
UC2	500	155	ALL	5	2400-0312	Retaining ring drawtube adapter
UC2	500	155	ALL	20	2400-0610	Wedge bar assembly UC2 500-155
UC2	500	155	ALL	7	2400-0152	Wedge bar UC2 500-155
UC2	500	155	ALL	8	2400-0172	Rack, wedge bar UC2 500-155
UC2	500	155	ALL	9	2400-0192	Cam, wedge bar rack UC2 500-155
UC2	500	155	ALL	10	2400-0212	Pin, jaw pre-position UC2 500-155
UC2	500	155	ALL	11	2400-0232	Cam bolt UC2 500-155
UC2	500	155	ALL	12	2400-0252	Cam pin UC2 500-155
UC2	500	155	ALL	14	2400-0270	Pin, keeper UC2 400/500 (OLD)
UC2	500	155	ALL	14/16	2400-0273	Pin, keeper UC2 500 (NEW)
UC2	500	155	ALL	14/16	2400-0472	Plug for keep pin
UC2	500	155	ALL	15	2400-0292	Guide bushing UC2 500-155
UC2	500	155	ALL	17	2400-0330	Pin UC2 400/500
UC2	500	155	ALL	18	2400-0352	Cap, Spring UC2 500-155
UC2	500	155	ALL	21	1192-2250	Base jaw wth cap screws

ATS Systems (Formerly SMW Systems)  
Ultimate Chuck (UC2) Spare Parts List

UC2	500	155	ALL	22	80-0226	Socket head cap screw M16X50
UC2	500	155	3Z	26a	80-0257	Socket head cap screw M20X130
UC2	500	155	A11	26b	80-0311	Socket head cap screw M20x180
UC2	500	155	A15	26c	80-0257	Socket head cap screw M20x130
UC2	500	155	3Z	27a		Socket head cap screw M24x170
UC2	500	155	A11	27b		Socket head cap screw M24x130
UC2	500	155	A15	27c		Socket head cap screw M24x190
UC2	500	155	ALL	29	80-0815	Socket head cap screw M8X45
UC2	500	155	ALL	30	80-1151	Screw special UC2 500-155
UC2	500	155	ALL	31	2400-0372	Pin
UC2	500	155	ALL	34	2200-7019	Fitting grease M6X1
UC2	500	155	ALL	36		Plug
UC2	500	155	ALL	38	1142-2626	Ball steel 6.0 mm
UC2	500	155	ALL	39	1142-2615	Ball steel 7.0 mm
UC2	500	155	ALL	40		Plug, blance correction
UC2	500	155	ALL	42	2400-0450	Spring
UC2	500	155	ALL	43	2400-0456	Spring
UC2	500	155	ALL	44	2400-0466	Spring
UC2	500	155	ALL	47	2400-0386	Wrench, jaw change 400/630
UC2	500	155	ALL	48	2400-0392	Effector, cam pin 400/500
UC2	500	155	ALL	51	2400-0412	Wrench, drawtube adjusting
UC2	500	155	ALL	60	2400-0432	Wrench, retaining ring
UC2	630	167	3Z		2403-0810	UC2-630-167 3Z 520 Chuck assembly
UC2	630	167	A11		2403-0820	UC2-630-167 A-11 Chuck assembly
UC2	630	167	A15		2403-0830	UC2-630-167 A-15 Chuck assembly
UC2	630	167	ALL	1	2400-0114	Chuck body - UC2 630-167
UC2	630	167	3Z	2a	2400-1800	Backplate, UC2 630-167 3Z 520
UC2	630	167	A11	2b	2400-1810	Backplate, UC2 630-167 A11
UC2	630	167	A15	2c	2400-1820	Backplate, UC2 630-167 A15
UC2	630	167	ALL	3	2400-0134	Actuator UC2 630-167
UC2	630	167	ALL	4	2400-0054	Blank drawtube adapter UC2 630-167
UC2	630	167	ALL	5	2400-0314	Retaining ring drawtube adapter
UC2	630	167	ALL	20	2400-0612	Wedge bar assembly UC2 630-167
UC2	630	167	ALL	7	2400-0154	Wedge bar UC2 630-167
UC2	630	167	ALL	8	2400-0174	Rack, wedge bar UC2 630-167
UC2	630	167	ALL	9	2400-0194	Cam, wedge bar rack UC2 630-167
UC2	630	167	ALL	10	2400-0214	Pin, jaw pre-position UC2 630-167
UC2	630	167	ALL	11	2400-0234	Cam bolt UC2 630-167
UC2	630	167	ALL	12	2400-0254	Cam pin UC2 630-167
UC2	630	167	ALL	14	2400-0274	Pin, keeper UC2 630-167 (OLD)
UC2	630	167	ALL	14/16	2400-0275	Pin, keeper UC2 630-167 (NEW)
UC2	630	167	ALL	14/16	2400-0474	Plug for keep pin
UC2	630	167	ALL	15	2400-0294	Guide bushing UC2 630-167
UC2	630	167	ALL	17	2400-0334	Pin UC2 630-167

ATS Systems (Formerly SMW Systems)  
Ultimate Chuck (UC2) Spare Parts List

UC2	630	167	ALL	18	2400-0352	Cap, Spring UC2 630-167
UC2	630	167	ALL	21	1192-2263	Base jaw with cap screws
UC2	630	167	ALL	22	80-0226	Socket head cap screw M16X50
UC2	630	167	3Z	26a	80-1032	Socket head cap screw M24X140
UC2	630	167	A11	26b		
UC2	630	167	A15	26c		
UC2	630	167	3Z	27a	80-1129	Socket head cap screw M24x190
UC2	630	167	A11	27b		
UC2	630	167	A15	27c		
UC2	630	167	ALL	29		Socket head cap screw M8X45
UC2	630	167	ALL	30	80-1151	Screw special UC2 630-167
UC2	630	167	ALL	31	2400-0372	Pin
UC2	630	167	ALL	34	2200-7019	Fitting grease M6X1
UC2	630	167	ALL	36		Plug
UC2	630	167	ALL	38	1142-2626	Ball steel 6.0 mm
UC2	630	167	ALL	39	1142-2615	Ball steel 7.0 mm
UC2	630	167	ALL	40		Plug, blance correction
UC2	630	167	ALL	42	2400-0450	Spring
UC2	630	167	ALL	43	2400-0456	Spring
UC2	630	167	ALL	44	2400-0466	Spring
UC2	630	167	ALL	47	2400-0386	Wrench, jaw change 400/630
UC2	630	167	ALL	48	2400-0394	Effector, cam pin 630-16
UC2	630	167	ALL	51	2400-0414	Wrench, drawtube adjusting
UC2	630	167	ALL	60	2400-0434	Wrench, retaining ring
UC2-B	210	52	3Z		2404-0210	UC2-B210-52 3Z Chuck assembly
UC2-B	210	52	A6		2404-0220	UC2-B210-52 A-6 Chuck assembly
UC2-B	210	52	A8		2404-0230	UC2-B210-52 A-8 Chuck assembly
UC2-B	210	52	All	1	2400-0800	Chuck body - UC2 B210-52
UC2-B	210	52	3Z	2a	2400-1202	Backplate, UC2B 210-52 3Z
UC2-B	210	52	A6	2b	2400-1212	Backplate, UC2B 210-52 3A6
UC2-B	210	52	A8	2c	2400-1222	Backplate, UC2B 210-52 3A8
UC2-B	210	52	All	3	2400-0122	Actuator UC2 210-52
UC2-B	210	52	All	4	2400-0042	Blank drawtube adapter UC2 210-52
UC2-B	210	52	All	5	2400-0302	Retaining ring drawtube adapter
UC2-B	210	52	All	20	2400-0602	Wedge bar assembly UC2 210/225
UC2-B	210	52	All	7	2400-0142	Wedge bar UC2 210/225
UC2-B	210	52	All	8	2400-0162	Rack, wedge bar UC2 210/225
UC2-B	210	52	All	9	2400-0182	Cam, wedge bar rack UC2 210/225
UC2-B	210	52	All	10	2400-0202	Pin, jaw pre-position UC2 210/225
UC2-B	210	52	All	11	2400-0222	Cam bolt UC2 210/225
UC2-B	210	52	All	12	2400-0242	Cam pin UC2 210/225
UC2-B	210	52	All	14	2400-0262	Pin, keeper UC2 210/225 (OLD)
UC2-B	210	52	All	14	2400-0263	Pin, keeper UC2 210/225 (NEW)
UC2-B	210	52	All	16	n/a	Not Required

ATS Systems (Formerly SMW Systems)  
Ultimate Chuck (UC2) Spare Parts List

UC2-B	210	52	All	15	2400-0850	Guide bushing UC2 B210-52
UC2-B	210	52	All	17	2400-0322	Pin UC2 210/315
UC2-B	210	52	All	18	2400-0342	Cap, Spring UC2 210/400
UC2-B	210	52	All	21	2200-0014	Base jaw with cap screws
UC2-B	210	52	All	22		Socket head cap screw 1/2-13
UC2-B	210	52	3Z	26a	80-0656	Socket head cap screw M16X80
UC2-B	210	52	A6	26b	80-0656	Socket head cap screw M16X80
UC2-B	210	52	A8	26c	80-0305	Socket head cap screw M16X120
UC2-B	210	52	3Z	27a	80-1011	Socket head cap screw M12X105
UC2-B	210	52	A6	27b	80-0252	Socket head cap screw M12X120
UC2-B	210	52	A8	27c	80-0657	Socket head cap screw M12X80
UC2-B	210	52	All	29	80-0685	Socket head cap screw M5X25
UC2-B	210	52	All	30	80-0956	Screw special UC2 210-52
UC2-B	210	52	All	31	2400-0362	Pin
UC2-B	210	52	All	34	2200-7019	Fitting grease M6X1
UC2-B	210	52	All	36		Plug
UC2-B	210	52	All	38	1142-2626	Ball steel 6.0 mm
UC2-B	210	52	All	39	1142-2615	Ball steel 7.0 mm
UC2-B	210	52	All	40		Plug, blance correction
UC2-B	210	52	All	42	2400-0442	Spring
UC2-B	210	52	All	43	2400-0456	Spring
UC2-B	210	52	All	44	2400-0462	Spring
UC2-B	210	52	All	47	2400-0386	Wrench, jaw change 170/315
UC2-B	210	52	All	48	2400-0390	Effector, cam pin 170/315
UC2-B	210	52	All	51	2400-0402	Wrench, drawtube adjusting
UC2-B	210	52	All	55	-	Not Required
UC2-B	210	52	All	60	2400-0422	Wrench, retaining ring
UC2-B	225	68	3Z		2404-0310	UC2-B225-68 3Z Chuck assembly
UC2-B	225	68	A6		2404-0320	UC2-B225-68 A-6 Chuck assembly
UC2-B	225	68	A8		2404-0330	UC2-B225-68 A-8 Chuck assembly
UC2-B	225	68	All	1	2400-0802	Chuck body - UC2 B225-68
UC2-B	225	68	3Z	2a	2400-1302	Backplate, UC2B 225-68 3Z
UC2-B	225	68	A6	2b	2400-1312	Backplate, UC2B 225-68 3A6
UC2-B	225	68	A8	2c	2400-1322	Backplate, UCB2 225-68 3A8
UC2-B	225	68	All	3	2400-0124	Actuator UC2 225-68
UC2-B	225	68	All	4	2400-0044	Blank drawtube adapter UC2 210-52
UC2-B	225	68	All	5	2400-0304	Retaining ring drawtube adapter
UC2-B	225	68	All	20	2400-0602	Wedge bar assembly UC2 210/225
UC2-B	225	68	All	7	2400-0142	Wedge bar UC2 210/225
UC2-B	225	68	All	8	2400-0162	Rack, wedge bar UC2 210/225
UC2-B	225	68	All	9	2400-0182	Cam, wedge bar rack UC2 210/225
UC2-B	225	68	All	10	2400-0202	Pin, jaw pre-position UC2 210/225
UC2-B	225	68	All	11	2400-0222	Cam bolt UC2 210/225
UC2-B	225	68	All	12	2400-0242	Cam pin UC2 210/225

ATS Systems (Formerly SMW Systems)  
Ultimate Chuck (UC2) Spare Parts List

UC2-B	225	68	All	14	2400-0262	Pin, keeper UC2 210/225 (OLD)
UC2-B	225	68	All	14	2400-0263	Pin, keeper UC2 210/225 (NEW)
UC2-B	225	68	All	16		n/a
UC2-B	225	68	All	15	2400-0852	Guide bushing UC2 B225-68
UC2-B	225	68	All	17	2400-0322	Pin UC2 210/315
UC2-B	225	68	All	18	2400-0342	Cap, Spring UC2 210/400
UC2-B	225	68	All	21	2200-0014	Base jaw with screws
UC2-B	225	68	All	22		Socket head cap screw 1/2-13
UC2-B	225	68	3Z	26a	80-0656	Socket head cap screw M16X80
UC2-B	225	68	A6	26b	80-0656	Socket head cap screw M16X80
UC2-B	225	68	A8	26c	80-0305	Socket head cap screw M16X120
UC2-B	225	68	3Z	27a	80-1011	Socket head cap screw M12X105
UC2-B	225	68	A6	27b	80-0252	Socket head cap screw M12X120
UC2-B	225	68	A8	27c	80-0657	Socket head cap screw M12X80
UC2-B	225	68	All	29	80-0685	Socket head cap screw M5X25
UC2-B	225	68	All	30	80-0956	Screw special UC2 210-52
UC2-B	225	68	All	31	2400-0362	Pin
UC2-B	225	68	All	34	2200-7019	Fitting grease M6X1
UC2-B	225	68	All	36		Plug
UC2-B	225	68	All	38	1142-2626	Ball steel 6.0 mm
UC2-B	225	68	All	39	1142-2615	Ball steel 7.0 mm
UC2-B	225	68	All	40		Plug, blance correction
UC2-B	225	68	All	42	2400-0442	Spring
UC2-B	225	68	All	43	2400-0456	Spring
UC2-B	225	68	All	44	2400-0462	Spring
UC2-B	225	68	All	47	2400-0386	Wrench, jaw change 170/315
UC2-B	225	68	All	48	2400-0390	Effector, cam pin 170/315
UC2-B	225	68	All	51	2400-0404	Wrench, drawtube adjusting
UC2-B	225	68	All	55	-	Not Required
UC2-B	225	68	All	60	2400-0424	Wrench, retaining ring
UC2-B	265	77	3Z		2404-0410	UC2-B265-77 3Z Chuck assembly
UC2-B	265	77	A6		2404-0420	UC2-B265-77 A-6 Chuck assembly
UC2-B	265	77	A8		2404-0430	UC2-B265-77 A-8 Chuck assembly
UC2-B	265	77	All	1	2400-0804	Chuck body - UC2 B265-77
UC2-B	265	77	3Z	2a	2400-1402	Backplate, UC2B 265-77 3Z
UC2-B	265	77	A6	2b	2400-1412	Backplate, UC2B 265-77 3A6
UC2-B	265	77	A8	2c	2400-1422	Backplate, UC2B 265-77 3A8
UC2-B	265	77	All	3	2400-0126	Actuator UC2 265-77
UC2-B	265	77	All	4	2400-0046	Blank drawtube adapter UC2 265-77
UC2-B	265	77	All	5	2400-0306	Retaining ring drawtube adapter
UC2-B	265	77	All	20	2400-0604	Wedge bar assembly UC2 265-77
UC2-B	265	77	All	7	2400-0146	Wedge bar UC2 265-77
UC2-B	265	77	All	8	2400-0166	Rack, wedge bar UC2 265-77
UC2-B	265	77	All	9	2400-0186	Cam, wedge bar rack UC2 265-77

ATS Systems (Formerly SMW Systems)  
Ultimate Chuck (UC2) Spare Parts List

UC2-B	265	77	All	10	2400-0206	Pin, jaw pre-position UC2 265-77
UC2-B	265	77	All	11	2400-0226	Cam bolt UC2 265-77
UC2-B	265	77	All	12	2400-0246	Cam pin UC2 265-77
UC2-B	265	77	All	14	2400-0266	Pin, keeper UC2 265-77 (OLD)
UC2-B	265	77	All	14/16	2400-0267	Pin, keeper UC2 265-77 (NEW)
UC2-B	265	77	All	14/16	2400-0472	Plug for keep pin
UC2-B	265	77	All	15	2400-0854	Guide bushing UC2 265-77
UC2-B	265	77	All	17	2400-0322	Pin UC2 210/315
UC2-B	265	77	All	18	2400-0342	Cap, Spring UC2 210/400
UC2-B	265	77	All	21	2200-0015	Base jaw with cap screws
UC2-B	265	77	All	22		Socket head cap screw 5/8-11
UC2-B	265	3Z	All	26a	80-0885	Socket head cap screw M16X90
UC2-B	265	A6	All	26b	80-0885	Socket head cap screw M16X90
UC2-B	265	A8	All	26c	80-0883	Socket head cap screw M16X140
UC2-B	265	3Z	All	27a		Socket head cap screw M12X135
UC2-B	265	A6	All	27b	80-1038	Socket head cap screw M12X140
UC2-B	265	A8	All	27c	80-0428	Socket head cap screw M12X90
UC2-B	265	77	All	29		Socket head cap screw M5X30
UC2-B	265	77	All	30	80-0956	Screw special UC2 265-77
UC2-B	265	77	All	31	2400-0366	Pin
UC2-B	265	77	All	34	2200-7019	Fitting grease M6X1
UC2-B	265	77	All	36		Plug
UC2-B	265	77	All	38	1142-2626	Ball steel 6.0 mm
UC2-B	265	77	All	39	1142-2615	Ball steel 7.0 mm
UC2-B	265	77	All	40		Plug, blance correction
UC2-B	265	77	All	42	2400-0442	Spring
UC2-B	265	77	All	43	2400-0456	Spring
UC2-B	265	77	All	44	2400-0462	Spring
UC2-B	265	77	All	47	2400-0386	Wrench, jaw change 170/315
UC2-B	265	77	All	48	2400-0390	Effector, cam pin 170/315
UC2-B	265	77	All	51	2400-0406	Wrench, drawtube adjusting
UC2-B	265	77	All	55	-	Not Required
UC2-B	265	77	All	60	2400-0426	Wrench, retaining ring
UC2-B	315	91	3Z		2404-0510	UC2-B315-91 3Z Chuck assembly
UC2-B	315	91	A8		2404-0520	UC2-B315-91 A-8 Chuck assembly
UC2-B	315	91	A11		2404-0530	UC2-B315-91 A-11 Chuck assembly
UC2-B	315	91	All	1	2400-0806	Chuck body - UC2 B315-91
UC2-B	315	91	3Z	2a	2400-1502	Backplate, UC2B 315-91 3Z
UC2-B	315	91	A8	2b	2400-1512	Backplate, UC2B 315-91 3A8
UC2-B	315	91	A11	2c	2400-1522	Backplate, UC2B 315-91 3A11
UC2-B	315	91	All	3	2400-0128	Actuator UC2 315-91
UC2-B	315	91	All	4	2400-0048	Blank drawtube adapter UC2 315-91
UC2-B	315	91	All	5	2400-0308	Retaining ring drawtube adapter
UC2-B	315	91	All	20	2400-0606	Wedge bar assembly UC2 315-91

ATS Systems (Formerly SMW Systems)  
Ultimate Chuck (UC2) Spare Parts List

UC2-B	315	91	All	7	2400-0148	Wedge bar UC2 315-91
UC2-B	315	91	All	8	2400-0168	Rack, wedge bar UC2 315-91
UC2-B	315	91	All	9	2400-0188	Cam, wedge bar rack UC2 315-91
UC2-B	315	91	All	10	2400-0208	Pin, jaw pre-position UC2 315-91
UC2-B	315	91	All	11	2400-0228	Cam bolt UC2 315-91
UC2-B	315	91	All	12	2400-0246	Cam pin UC2 265/315
UC2-B	315	91	All	14	2400-0266	Pin, keeper UC2 265/315 (OLD)
UC2-B	315	91	All	14/16	2400-0269	Pin, keeper UC2 315 (NEW)
UC2-B	315	91	All	14/16	2400-0472	Plug for keep pin
UC2-B	315	91	All	15	2400-0856	Guide bushing UC2 B315-104
UC2-B	315	91	All	17	2400-0322	Pin UC2 210/315
UC2-B	315	91	All	18	2400-0342	Cap, Spring UC2 210/400
UC2-B	315	91	All	21	2200-0016	Base jaw w/Cap screws
UC2-B	315	91	All	22		Socket head cap screw 5/8-11
UC2-B	315	91	3Z	26a		Socket head cap screw M20x105
UC2-B	315	91	A8	26b		Socket head cap screw M20x105
UC2-B	315	91	A11	26c	80-0615	Socket head cap screw M20X150
UC2-B	315	91	3Z	27a	80-0508	Socket head cap screw M16X135
UC2-B	315	91	A8	27b	80-0621	Socket head cap screw M16x155
UC2-B	315	91	A11	27c		Socket head cap screw M16X105
UC2-B	315	91	All	29	80-0156	Socket head cap screw M6X30
UC2-B	315	91	All	30	80-0956	Screw special UC2 315-91
UC2-B	315	91	All	31	2400-0366	Pin
UC2-B	315	91	All	34	2200-7019	Fitting grease M6X1
UC2-B	315	91	All	36		Plug
UC2-B	315	91	All	38	1142-2626	Ball steel 6.0 mm
UC2-B	315	91	All	39	1142-2615	Ball steel 7.0 mm
UC2-B	315	91	All	40		Plug, blance correction
UC2-B	315	91	All	42	2400-0446	Spring
UC2-B	315	91	All	43	2400-0456	Spring
UC2-B	315	91	All	44	2400-0462	Spring
UC2-B	315	91	All	47	2400-0386	Wrench, jaw change 170/315
UC2-B	315	91	All	48	2400-0390	Effector, cam pin 170/315
UC2-B	315	91	All	51	2400-0408	Wrench, drawtube adjusting
UC2-B	315	91	All	55	2400-0820	O-Ring UC2B 315 Size 140x2
UC2-B	315	91	All	60	2400-0428	Wrench, retaining ring
UC2-B	315	104	3Z		2404-0512	UC2-B315-104 3Z Chuck assembly
UC2-B	315	104	A8		2404-0522	UC2-B315-104 A-8 Chuck assembly
UC2-B	315	104	A11		2404-0532	UC2-B315-104 A-11 Chuck assembly
UC2-B	315	104	All	1	2400-0807	Chuck body - UC2 B315-104
UC2-B	315	104	3Z	2a	2400-1506	Backplate, UC2B 315-104 3Z/220
UC2-B	315	104	A8	2b	2400-1516	Backplate, UC2B 315-104 3A8
UC2-B	315	104	A11	2c	2400-1532	Backplate, UC2B 315-104 3A11
UC2-B	315	104	All	3	2400-0129	Actuator UC2B 315-104

ATS Systems (Formerly SMW Systems)  
Ultimate Chuck (UC2) Spare Parts List

UC2-B	315	104	All	4	2400-0049	Blank drawtube adapter UC2 315-104
UC2-B	315	104	All	5	2400-0309	Retaining ring drawtube adapter
UC2-B	315	104	All	20	2400-0606	Wedge bar assembly UC2 315-91&104
UC2-B	315	104	All	7	2400-0148	Wedge bar UC2 315-91&104
UC2-B	315	104	All	8	2400-0168	Rack, wedge bar UC2 315-91&104
UC2-B	315	104	All	9	2400-0188	Cam, wedge bar rack UC2 315-91&104
UC2-B	315	104	All	10	2400-0208	Pin, jaw pre-position UC2 315-91&104
UC2-B	315	104	All	11	2400-0229	Cam bolt UC2 315-104
UC2-B	315	104	All	12	2400-0246	Cam pin UC2 265/315
UC2-B	315	104	All	14	2400-0266	Pin, keeper UC2 265/315 (OLD)
UC2-B	315	104	All	14/16	2400-0269	Pin, keeper UC2 315 (NEW)
UC2-B	315	104	All	14/16	2400-0472	Plug for keep pin
UC2-B	315	104	All	15	2400-0857	Guide bushing UC2 B315-104
UC2-B	315	104	All	17	2400-0322	Pin UC2 210/315
UC2-B	315	104	All	18	2400-0342	Cap, Spring UC2 210/400
UC2-B	315	104	All	21	2200-0016	Base jaw w/Cap screws
UC2-B	315	104	All	22		Socket head cap screw 5/8-11
UC2-B	315	104	3Z	26a		Socket head cap screw M20x105
UC2-B	315	104	A8	26b		Socket head cap screw M20x105
UC2-B	315	104	A11	26c	80-0615	Socket head cap screw M20X150
UC2-B	315	104	3Z	27a	80-0508	Socket head cap screw M16X135
UC2-B	315	104	A8	27b	80-0621	Socket head cap screw M16x155
UC2-B	315	104	A11	27c		Socket head cap screw M16X105
UC2-B	315	104	All	29	80-0156	Socket head cap screw M6X30
UC2-B	315	104	All	30	80-0956	Screw special UC2 315-91
UC2-B	315	104	All	31	2400-0366	Pin
UC2-B	315	104	All	34	2200-7019	Fitting grease M6X1
UC2-B	315	104	All	36		Plug
UC2-B	315	104	All	38	1142-2626	Ball steel 6.0 mm
UC2-B	315	104	All	39	1142-2615	Ball steel 7.0 mm
UC2-B	315	104	All	40		Plug, blance correction
UC2-B	315	104	All	42	2400-0446	Spring
UC2-B	315	104	All	43	2400-0456	Spring
UC2-B	315	104	All	44	2400-0462	Spring
UC2-B	315	104	All	47	2400-0386	Wrench, jaw change 170/315
UC2-B	315	104	All	48	2400-0390	Effector, cam pin 170/315
UC2-B	315	104	All	51	2400-0409	Wrench, drawtube adjusting
UC2-B	315	104	All	55	2400-0820	O-Ring UC2B 315 Size 140x2
UC2-B	315	104	All	60	2400-0429	Wrench, retaining ring
UC2-B	400	128	3Z		2404-0610	UC2B-400-128 3Z-300 Chuck assembly
UC2-B	400	128	3Z		2404-0615	UC2B-400-128 3Z-380 Chuck assembly
UC2-B	400	128	A11		2404-0620	UC2B-400-128 A-11 Chuck assembly
UC2-B	400	128	A15		2404-0630	UC2B-400-128 A-15 Chuck assembly
UC2-B	400	128	All	1	2400-0808	Chuck body - UC2 B400-128

ATS Systems (Formerly SMW Systems)  
Ultimate Chuck (UC2) Spare Parts List

UC2-B	400	128	3Z	2a	2400-1602	Backplate, UC2B 400-128 3Z-300
UC2-B	400	128	3Z	2b	2400-1612	Backplate, UC2B 400-128 3Z-380
UC2-B	400	128	A11	2c	2400-1622	Backplate, UC2B 400-128 3A11
UC2-B	400	128	A15	2d	2400-1630	Backplate, UC2 400-128 3A15
UC2-B	400	128	All	3	2400-0130	Actuator UC2 400-128
UC2-B	400	128	All	4	2400-0050	Blank drawtube adapter UC2 400-128
UC2-B	400	128	All	5	2400-0310	Retaining ring drawtube adapter
UC2-B	400	128	All	20	2400-0608	Wedge bar assembly UC2 400-128
UC2-B	400	128	All	7	2400-0150	Wedge bar UC2 400-128
UC2-B	400	128	All	8	2400-0170	Rack, wedge bar UC2 400-128
UC2-B	400	128	All	9	2400-0190	Cam, wedge bar rack UC2 400-128
UC2-B	400	128	All	10	2400-0210	Pin, jaw pre-position UC2 400-128
UC2-B	400	128	All	11	2400-0230	Cam bolt UC2 400-128
UC2-B	400	128	All	12	2400-0250	Cam pin UC2 400-128
UC2-B	400	128	All	14	2400-0270	Pin, keeper UC2 400/500 (OLD)
UC2-B	400	128	All	14/16	2400-0271	Pin, keeper UC2 400 (NEW)
UC2-B	400	128	All	14/16	2400-0472	Plug for keep pin
UC2-B	400	128	All	15	2400-0858	Guide bushing UC2 B400-128
UC2-B	400	128	All	17	2400-0330	Pin UC2 400/500
UC2-B	400	128	All	18	2400-0342	Cap, set screw UC2 210/400
UC2-B	400	128	All	21	2200-0017	Base jaw with cap screws
UC2-B	400	128	All	22		Socket head cap screw 3/4-10
UC2-B	400	128	3Z	26a	80-0503	Socket head cap screw M20x140
UC2-B	400	128	3Z	26b		Socket head cap screw M24x150
UC2-B	400	128	A11	26c	80-0421	Socket head cap screw M20x160
UC2-B	400	128	A15	26d	80-0447	Socket head cap screw M20x110
UC2-B	400	128	3Z	27a	80-1091	Socket head cap screw M24x120
UC2-B	400	128	3Z	27b	80-0447	Socket head cap screw M20x110
UC2-B	400	128	A11	27c		Socket head cap screw M24x130
UC2-B	400	128	A15	27d		Socket head cap screw M24x160
UC2-B	400	128	All	29	80-0156	Socket head cap screw M6X30
UC2-B	400	128	All	30	80-1151	Screw special UC2 400-128
UC2-B	400	128	All	31	2400-0370	Pin
UC2-B	400	128	All	34	2200-7019	Fitting grease M6X1
UC2-B	400	128	All	36		Plug
UC2-B	400	128	All	38	1142-2626	Ball steel 6.0 mm
UC2-B	400	128	All	39	1142-2615	Ball steel 7.0 mm
UC2-B	400	128	All	40		Plug, blance correction
UC2-B	400	128	All	42	2400-0446	Spring
UC2-B	400	128	All	43	2400-0456	Spring
UC2-B	400	128	All	44	2400-0466	Spring
UC2-B	400	128	All	47	2400-0386	Wrench, jaw change 400/630
UC2-B	400	128	All	48	2400-0392	Effector, cam pin 400/500
UC2-B	400	128	All	51	2400-0410	Wrench, drawtube adjusting

ATS Systems (Formerly SMW Systems)  
Ultimate Chuck (UC2) Spare Parts List

UC2-B	400	128	All	55	2400-0822	O-Ring UC2B 400 Size 175x2.5
UC2-B	400	128	All	60	2400-0430	Wrench, retaining ring
UC2-B	500	155	3Z		2404-0710	UC2-B500-155 3Z 380 Chuck assembly
UC2-B	500	155	A11		2404-0720	UC2-B500-155 A-11 Chuck assembly
UC2-B	500	155	A15		2404-0730	UC2-B500-155 A-15 Chuck assembly
UC2-B	500	155	All	1	2400-0810	Chuck body - UC2 B500-155
UC2-B	500	155	3Z	2a	2400-1702	Backplate, UC2B 500-155 3Z
UC2-B	500	155	A11	2b	2400-1712	Backplate, UC2B 500-155 A11
UC2-B	500	155	A15	2c	2400-1722	Backplate, UC2B 500-155 A15
UC2-B	500	155	All	3	2400-0132	Actuator UC2 500-155
UC2-B	500	155	All	4	2400-0052	Blank drawtube adapter UC2 500-155
UC2-B	500	155	All	5	2400-0312	Retaining ring drawtube adapter
UC2-B	500	155	All	20	2400-0610	Wedge bar assembly UC2 500-155
UC2-B	500	155	All	7	2400-0152	Wedge bar UC2 500-155
UC2-B	500	155	All	8	2400-0172	Rack, wedge bar UC2 500-155
UC2-B	500	155	All	9	2400-0192	Cam, wedge bar rack UC2 500-155
UC2-B	500	155	All	10	2400-0212	Pin, jaw pre-position UC2 500-155
UC2-B	500	155	All	11	2400-0232	Cam bolt UC2 500-155
UC2-B	500	155	All	12	2400-0252	Cam pin UC2 500-155
UC2-B	500	155	All	14	2400-0270	Pin, keeper UC2 400/500 (OLDER SEE NOTE)
UC2-B	500	155	All	14/16	2400-0273	Pin, keeper UC2 500
UC2-B	500	155	All	14/16	2400-0472	Plug for keep pin
UC2-B	500	155	All	15	2400-0860	Guide bushing UC2 B500-155
UC2-B	500	155	All	17	2400-0330	Pin UC2 400/500
UC2-B	500	155	All	18	2400-0352	Cap, set screw UC2 500-155
UC2-B	500	155	All	21	2200-0018	Base jaw with cap screws
UC2-B	500	155	All	22		Socket head cap screw 3/4-10
UC2-B	500	155	3Z	26a	80-0257	Socket head cap screw M20X130
UC2-B	500	155	A11	26b	80-0311	Socket head cap screw M20x180
UC2-B	500	155	A15	26c	80-0257	Socket head cap screw M20x130
UC2-B	500	155	3Z	27a		Socket head cap screw M24x170
UC2-B	500	155	A11	27b		Socket head cap screw M24x130
UC2-B	500	155	A15	27c		Socket head cap screw M24x190
UC2-B	500	155	All	29	80-0815	Socket head cap screw M8X45
UC2-B	500	155	All	30	80-1151	Screw special UC2 500-155
UC2-B	500	155	All	31	2400-0372	Pin
UC2-B	500	155	All	34	2200-7019	Fitting grease M6X1
UC2-B	500	155	All	36		Plug
UC2-B	500	155	All	38	1142-2626	Ball steel 6.0 mm
UC2-B	500	155	All	39	1142-2615	Ball steel 7.0 mm
UC2-B	500	155	All	40		Plug, blance correction
UC2-B	500	155	All	42	2400-0450	Spring
UC2-B	500	155	All	43	2400-0456	Spring
UC2-B	500	155	All	44	2400-0466	Spring

ATS Systems (Formerly SMW Systems)  
Ultimate Chuck (UC2) Spare Parts List

UC2-B	500	155	All	47	2400-0386	Wrench, jaw change 400/630
UC2-B	500	155	All	48	2400-0392	Effector, cam pin 400/500
UC2-B	500	155	All	51	2400-0412	Wrench, drawtube adjusting
UC2-B	500	155	All	55	2400-0824	O-Ring UC2B-500 Size 202x2.5
UC2-B	500	155	All	60	2400-0432	Wrench, retaining ring
UC2-B	630	167	3Z		2404-0810	UC2-B630-167 3Z 520 Chuck assembly
UC2-B	630	167	A11		2404-0820	UC2-B630-167 A-11 Chuck assembly
UC2-B	630	167	A15		2404-0830	UC2-B630-167 A-15 Chuck assembly
UC2-B	630	167	All	1	2400-0812	Chuck body - UC2 B630-167
UC2-B	630	167	3Z	2a	2400-1802	Backplate, UC2B 630-167 3Z 520
UC2-B	630	167	A11	2b	2400-1812	Backplate, UC2B 630-167 A11
UC2-B	630	167	A15	2c	2400-1822	Backplate, UC2B 630-167 A15
UC2-B	630	167	All	3	2400-0134	Actuator UC2 630-167
UC2-B	630	167	All	4	2400-0054	Blank drawtube adapter UC2 630-167
UC2-B	630	167	All	5	2400-0314	Retaining ring drawtube adapter
UC2-B	630	167	All	20	2400-0612	Wedge bar assembly UC2 630-167
UC2-B	630	167	All	7	2400-0154	Wedge bar UC2 630-167
UC2-B	630	167	All	8	2400-0174	Rack, wedge bar UC2 630-167
UC2-B	630	167	All	9	2400-0194	Cam, wedge bar rack UC2 630-167
UC2-B	630	167	All	10	2400-0214	Pin, jaw pre-position UC2 630-167
UC2-B	630	167	All	11	2400-0234	Cam bolt UC2 630-167
UC2-B	630	167	All	12	2400-0254	Cam pin UC2 630-167
UC2-B	630	167	All	14	2400-0274	Pin, keeper UC2 630-167 (OLD)
UC2-B	630	167	All	14/16	2400-0275	Pin, keeper UC2 630-167 (NEW)
UC2-B	630	167	All	14/16	2400-0474	Plug for keep pin
UC2-B	630	167	All	15	2400-0862	Guide bushing UC2 B630-167
UC2-B	630	167	All	17	2400-0334	Pin UC2 630-167
UC2-B	630	167	All	18	2400-0352	Cap, set screw UC2 630-167
UC2-B	630	167	All	21	1192-4463	Base jaw with cap screws
UC2-B	630	167	All	22		Socket head cap screw 3/4-10
UC2-B	630	167	All	3Z	80-1032	Socket head cap screw M24X140
UC2-B	630	167	All	A11		
UC2-B	630	167	All	A15		
UC2-B	630	167	All	3Z	80-1129	Socket head cap screw M24x190
UC2-B	630	167	All	A11		
UC2-B	630	167	All	A15		
UC2-B	630	167	All	29		Socket head cap screw M8X45
UC2-B	630	167	All	30	80-1151	Screw special UC2 630-167
UC2-B	630	167	All	31	2400-0372	Pin
UC2-B	630	167	All	34	2200-7019	Fitting grease M6X1
UC2-B	630	167	All	36		Plug
UC2-B	630	167	All	38	1142-2626	Ball steel 6.0 mm
UC2-B	630	167	All	39	1142-2615	Ball steel 7.0 mm
UC2-B	630	167	All	40		Plug, blance correction

ATS Systems (Formerly SMW Systems)  
Ultimate Chuck (UC2) Spare Parts List

UC2-B	630	167	All	42	2400-0450	Spring
UC2-B	630	167	All	43	2400-0456	Spring
UC2-B	630	167	All	44	2400-0466	Spring
UC2-B	630	167	All	47	2400-0386	Wrench, jaw change 400/630
UC2-B	630	167	All	48	2400-0394	Effector, cam pin 630-16
UC2-B	630	167	All	51	2400-0414	Wrench, drawtube adjusting
UC2-B	630	167	All	55	2400-0826	O-Ring UC2B Size 230x2.5
UC2-B	630	167	All	60	2400-0434	Wrench, retaining ring

## 6.2 Operator Training on the Ultimate Chuck model UC 2

*The following is taken from the Installation & Training checklist used by ATS Systems Service Engineers when installing Ultimate Chucks and training operators. We recommend that shop supervisors use this document to assist them to train new operators when they are first assigned to use the Ultimate Chuck. Most of what is presented here applies to all types of power chucks.*

High speed lathes and chucks are perhaps the most hazardous equipment in most machine shops. Lathes and chucks have been designed and built with your safety in mind and have many safety features, guards and interfaces. But, the only way to prevent accidents and possible injury is to understand the hazards and to follow all the proper rules, recommendations, and general and specific safe shop practices. People are regularly injured and even killed as a result of "accidents" involving chucks. 99% of the time the accident is the result of operator error or lack of experience and training, not as a result of any failure of the equipment. Please listen carefully, ask questions and refuse to operate this equipment if you are unsure how to operate it safely. The life you save may be your own.

### The bad things that can happen and the most common causes.

1. If a jaw were to come off of a spinning chuck it will become a projectile traveling in a straight line and could penetrate the heaviest guard. There is a high likelihood of serious injury here and fatalities are not uncommon.

Possible causes:

- Bolts too short, inadequate thread engagement, threads strip off.
- Bolts not properly torqued tight and come loose.
- Wrong grade of bolts and they break.
- Excessively tall jaws and even moderate grip forces can put severe tension on bolts and cause them to break.
- RPM way too high for an oversize jaw and the bolts actually shear. (Watch out when using constant surface feet programming!)
- Base jaw not engaged to "Safe" zone
- Poor quality or poor design jaw actually breaks and a portion of the jaw becomes a projectile. An example would be some types of welded jaws, cast jaws that can break, or a hard jaw that is improperly hardened (through hardened) and becomes brittle.

2. If a part is not securely clamped it can be thrown from the chuck. Unless it is struck by a spinning jaw as it exits it will not be traveling in a straight line and there is a good chance a heavy guard will stop it but it may not. Fatal accidents have happened.

Possible causes:

- RPM too high for the jaw selected, loss of grip force due to centrifugal force, part is released.
- Part inadequately gripped due to lack of proper chuck lubrication and resulting low grip force.
- Part inadequately gripped and pulled from jaw by an aggressive cutting tool.

## ATS Systems Ultimate Chuck Installation and Operations Manual

- Part inadequately gripped due to poor choice of top jaw and pulled from jaw by even light cutting tool force. (Such as soft jaws gripping an irregular rough casting.)
- Jaw positioned incorrectly or major workpiece gripping diameter variation (castings) causes jaw stroke to reach bottom before properly gripping the workpiece. (Some lathes with some styles of stroke control will protect from this.)
- Part inadequately gripped because the hydraulic pressure and resulting grip force is too low for the application.
- The chuck actually breaks at some critical component either because the drawbar pull is way over the maximum rating, or the chuck is used and fatigued for an extended time at a drawbar pull that is perhaps only 20% over the maximum rating.

Now that I have your attention, we will go step by step through the safe operating practices of the Ultimate Chuck. Note that all of what I've just said about the hazards and what I will now say about how to deal with them applies to all power chucks, not just the Ultimate Chuck.

- I have attached this maintenance and safety decal to your lathe. It summarizes the points I will now cover and I encourage you to review it regularly.
- This is the Installation, Operation and Maintenance Manual. It contains all the information I am going to present and more. Please read it carefully and pay special attention to safety items in sections 1.1 through 1.3.8, safe jaw positioning in section 4.2 – 4.3, calculating safe operating speed for different top jaws in section 4.5, and proper lubrication in section 5.2.

My training will now cover the following topics:

1. Safe chuck speed.
2. Changing, positioning and mounting jaws for safe operation.
3. Proper chuck lubrication.
4. Hydraulic pressure and proper drawbar / drawtube pull.
5. Chuck inspection and some miscellaneous safety instructions.

- Safe chuck speed (RPM) is greatly influenced by the top jaws used. The maximum rated speed of this chuck is \_\_\_\_ and applies only for normal chucking applications using the maximum rated drawbar pull and only for standard top jaws such as our Deep Bite Job Shop Jaw. For any other top jaws or conditions, speed must be reduced.

Always use the smallest, lightest, shortest jaw possible, and position it as close to centerline as possible. Centrifugal force pulls on all jaws and reduces actual grip force. The further out from centerline and the heavier the jaw, the higher the centrifugal force. When you do use oversize jaws or even standard jaws if they are positioned very far out from centerline, you need to determine a safe operating speed. You can either do this by using a dynamic grip force gauge and slowly raise the RPM until 50% of the initial grip force remains, or you can weigh the master base jaw and top jaw combination and make some simple calculations as shown in the manual section 4.4. *Demonstrate how to remove the bolted together base and top jaw, to weigh it, to balance it in a knife edge to determine and mark the center of gravity, to reinstall the jaw and measure the distance from centerline to the CG of the jaw assembly when the jaw is in the proper position for the particular job,*

## ATS Systems Ultimate Chuck Installation and Operations Manual

and how to make the calculations by taking them either through their actual setup or examples #3 and #4 in the manual section 4.5.

Note that you can also use this technique and formulas to calculate the approximate safe speed of standard chucks, but you must weigh and measure not only the top jaw but also the master jaw, bolts and T-nuts as an assembly. If you don't include the master jaws you will calculate a speed that's way too high. Of course, this requires you to disassemble the chuck which is impractical.

### Are there any questions?

- Now I want to talk about changing jaws, positioning jaws and bolting on jaws for safe operation.
- First, only use this special wrench to change jaws. A standard wrench will damage the chuck.
  - Never leave the wrench in the chuck.. If you start the lathe, the wrench can fly out and hit you. If you actuate the chuck with the wrench in, the chuck will be damaged.
  - Only use jaw mounting bolts that are marked grade 12.9, with threads in new condition, and long enough to engage a thread length 1 ½ - 2 times the diameter. Torque the bolts to the specification as shown in the manual (*Chuck size 170-225 M8 18-24 ft-lb; 265-400 M12 60-80 ft lb; 500-630 M16 140-180 ft lb.*) If you over torque, the base jaw may distort slightly and won't slide easily in the guideway.
  - Always position the inside end of the base jaw or monoblok jaw inside the "Safe" zone marked on the face of the chuck. Don't ever extend base jaws beyond this limit, and don't ever position any top jaw beyond the OD of the chuck more than a standard base jaw would extend when it is within the safe zone. *Demonstrate installing a jaw, point to the safe zone.*
  - Finally on the subject of positioning jaws, always position the jaw to grip the workpiece as close to the start of the jaw stroke as possible. The issue isn't that the chuck needs to operate near the start of the stroke, the issue is that you want to have extra stroke available in case one of your workpiece blanks is much smaller diameter than the blank you setup with. With the cylinder on this lathe, this chuck has a jaw stroke of \_\_\_\_". The adjustment pitch is \_\_\_\_". The maximum jaw stroke for this chuck is \_\_\_\_", so with this cylinder we are short stroking ....(a little bit, a lot, whatever describes this installation.)

UC2 Model	170	210	225	265	315	400	500	630
Adjustment	.189	.189	.189	.216	.216	.216	.275	.275
Max. Stroke	.22	.25	.25	.35	.36	.39	.45	.50

So when using hard jaws on this machine:

- a. (if the jaw stroke exceeds the adj. pitch more than .040") you might find two possible jaw positions that work. If so, choose the one that grips close to the start of the stroke.
- b. (if the jaw stroke is short) you will need to purchase a set of half-pitch base jaws and when necessary switch with your normal base jaws to grip close to the start of the jaw stroke.

It is very important that each time you chuck a part you note if you are near the end of the jaw stroke and risk not properly holding the part. If this happens, adjust all three jaws in one step and use half-pitch base jaws if necessary. (This point may be a bit confusing, so spend as much time as necessary until everyone understands.

- Are there any questions?

## ATS Systems Ultimate Chuck Installation and Operations Manual

Lubrication is important on any chuck. On this high-tech, high performance chuck it is particularly important. See manual sections 5.2 and 1.3.5.

- Unless the chuck is properly lubricated your grip force might only be 50% of what it would be with proper lubrication. You could throw parts.
- Use only ATS Systems' KO5 grease. Grease chuck every 24 hours of operation, two shots of KO5 per grease fitting with the chuck in the full "open-jaws out" position.
- Fully stroke the chuck (10) times after lubricating to distribute grease to internal components.
- At the start of each shift and after every 50 clamping cycles, actuate the chuck full stroke 5-10 times without gripping a workpiece to internally redistribute grease throughout the chuck.
- Clean jaw guideways when changing jaws, or at least once per shift if no jaw change is required, and lightly coat sliding jaw surfaces with KO5. (*Demonstrate sweeping chips out of the guideway located at the 6:00 position.*)

With the cylinder that is on this machine, (*decide if comment "a" or "b" below is appropriate. Usually it's "a". A "b" condition is rare.*)

- a. and with the maximum hydraulic pressure the machine has available, this chuck is operating at \_\_\_ % of it's maximum rated grip force. Note that the Ultimate Chuck's maximum grip force is probably 1.2-1.5 times that of a standard chuck and anything above 65% is typical. Also, to get the same static grip force as the standard chuck you need to increase the pressure 30%. So if you have pressure settings recorded for jobs you run on this machine, increase them by 30% up to the maximum. If you can't achieve the static grip force you had before it's probably not a problem. What you need isn't static grip force when the chuck isn't rotating, but remaining grip force when you are at cutting speed. Do the calculations for the jaws you are using or use a grip force gauge and limit your speed to a 50% grip force loss.
- b. the maximum hydraulic pressure the machine has available would give too much drawbar pull for this chuck and the chuck would be damaged. Because of this I've noted on this tag that the pressure should never be set above \_\_\_ PSI. For most any application you shouldn't need more than 90% of that pressure.

### Any questions?

Finally for some miscellaneous points.

- Never stand in line with a rotating chuck. Always stand off to one side so that if anything bad happens it's less likely to hit you.
- I recommend you purchase a dynamic grip force gauge and inspect the grip force of the chuck weekly and record it. If you note a decrease in grip force it's time to disassemble, clean and inspect the chuck. Under normal operating conditions it's wise to clean the chuck every 1000-1500 hours of operation.

**So, for a quick review:**

# ATS Systems Ultimate Chuck Installation and Operations Manual

- \_\_\_ Avoid standing directly in line with a rotating chuck or workpiece.
- \_\_\_ Don't forget the hazard of using non standard large jaws and even full wide soft jaws. Resulting centrifugal force may require RPM to be limited.
- \_\_\_ Use only grade 12.9 bolts in new condition for jaw mounting with a minimum of 1½ -2 times diameter thread engagement.
- \_\_\_ Use only the special ATS hex key to change jaws or chuck will be damaged. Never take your hand off the key. Never leave key in the chuck as it could fly out if spindle is rotated.
- \_\_\_ Increase hydraulic pressure 30% to achieve same static grip force as most standard chucks.
- \_\_\_ Always position the end of the base jaw inside the safe zone marked on the face of the chuck.
- \_\_\_ Set jaw adjustment to grip the part as close to the start of the jaw stroke as possible, especially when chucking irregular castings, forgings, etc. As you chuck each part, observe that adequate jaw stroke remains to grip the part.
- \_\_\_ If drawtube stroke and resulting jaw stroke is less than .050" more than the adjustment pitch, you need to use half pitch base jaws for hard jaw applications and to take care that you always setup to grip in the first part of the jaw stroke.
- \_\_\_ Chuck lubrication
  - Lubricate every 24 hours of operation with two shots of KO5 grease per fitting.
  - Lubricate with chuck in the fully open (jaws away from centerline) position only.
  - Fully stroke chuck (10) times after lubricating to distribute grease to internal components.
  - Fully stroke the chuck 5-10 times after each 50 parts and at the start of the shift
  - Clean and lubricate jaws whenever jaws are changed, or once per eight hour shift.

As part of a paid installation by ATS Systems, our Service Engineer will complete the following decal using data for your lathe and hydraulic cylinder (if data is available) and attach it to your lathe for future reference. This deals with the critical issues of jaw stroke and the use of hard jaws, and grip force.

ULTIMATE CNC CHUCK AND LATHE CYLINDER SPECIFICATIONS FOR THIS INSTALLATION	
Chuck Model _____	Cylinder Model _____
Max. Chuck piston stroke = _____"	Max. Cylinder piston stroke = _____"
Max. Chuck jaw stroke = _____"	Jaw stroke with this Cylinder = _____"
	(If jaw stroke is less than maximum, use half pitch base jaws as required for hard jaw applications.)
	Max. allowable Cylinder pressure = _____ psi.
	Max. Cylinder pull = _____ lbs. at max. pressure.
	Max. available machine pressure = _____ psi.
Max. Chuck drawbar pull = _____ lbs.	Cylinder pull at max machine pressure = _____ lbs.
- If cylinder pull at maximum machine pressure exceeds maximum chuck drawbar pull:	
<b>Limit cylinder pressure to _____ psi or damage to chuck will occur.</b>	
- If cylinder pull at maximum machine pressure is less than maximum chuck drawbar pull:	
<b>With this cylinder at the maximum available machine pressure, the chuck develops _____% of its maximum possible grip force.</b>	

## 6.2 Standard Terms, Conditions and General Product Warranty

All quotations of ATS SYSTEMS (ATS), all customer's/distributor's purchase orders, and all acknowledgments of customer's/distributor's purchase orders by ATS are made subject to written acceptance and acknowledgment delivered by ATS and are made subject to the following STANDARD TERMS AND CONDITIONS OF SALE, and ATS offers to sell its products and services only upon these terms and conditions.

1. **SALE PRICES:** All prices quoted are FOB shipping location and are subject to the terms of payment set forth in the final order acknowledged by ATS. All prices quoted are subject to change without notice at any time until confirmed by our acknowledgment in writing of your purchase order.
2. **SALES AND USE TAXES, OTHER CONSUMER TAXES:** Sales, use, excise, property or similar taxes arising out of or relating to the order of the equipment shipped pursuant to your purchase order are not included in the price except as otherwise specifically stated in the order or in the invoice. All such taxes are the responsibility of the Purchaser. ATS reserves the right at any time to separately bill the purchaser for any such tax which ATS may be called upon to pay or to collect on account of the sale of the equipment.
3. **ACCEPTANCE:** Your offer to purchase is an irrevocable offer to purchase, valid thirty (30) days after receipt by ATS. Your offer shall not be binding upon ATS or create any obligations on ATS's part unless and until ATS shall have accepted your purchase order at its home office in Santa Fe Springs, California. Such acceptance shall be made only by transmittal to you by ATS of ATS's written acceptance. After acceptance, the contract between us relating to the sale by ATS and the purchase by you of the equipment specified in the offer to purchase shall be specifically subject to these Standard Terms and Conditions of Sale, notwithstanding any other conditions of sale or purchase which may be contained in your purchase order. It is an express condition of ATS's acceptance of your purchase order that in the event of any conflict between any conditions of sale or purchase set forth in your purchase order and these Terms and Conditions of Sale, the latter shall be applicable in all events. After acceptance, the contract between us relating to the sale and purchase of the equipment shall be construed in accordance with the laws of the State of California.
4. **DELIVERY:** Unless stated in the order acknowledgment, no estimate has been made of the length of time required for delivery of the equipment covered by the order. If an estimate of time of delivery of the equipment has been made, it is approximate only and will begin to run at the date of ATS's acceptance of your purchase order. ATS shall not be responsible for delays caused by civil insurrection, war, fire, strikes, labor stoppages, acts of God, shortages of materials, the failure of suppliers or subcontractors to satisfactorily meet scheduled deliveries, the establishment of any priority system by the United States of America or any of its agencies, or any other factor or event beyond its control.
5. **TITLE, RISK OF LOSS:** Title shall not pass from ATS to the Purchaser until ATS has been paid in full for the equipment, and ATS shall retain a security interest in the equipment at all times until ATS has been paid in full. Upon delivery by ATS to a carrier for shipment of equipment to the Purchaser, risk of loss shall pass to the Purchaser. Thereafter, the carrier shall be deemed to be acting for and on behalf of the Purchaser, and the terms of payment for the equipment shall not be affected by damage to or destruction of the equipment sold.
6. **DELAYS AND CANCELLATIONS:** In the event that, after ATS's acceptance of your purchase order, you request ATS to delay shipment of the equipment, the purchase price shall become due and owing thirty (30) days after the equipment is ready for shipment. No requests for delays beyond the specified delivery date will be honored by ATS without ATS's expressed written consent. No order may be cancelled without the expressed written consent of ATS. In the event of cancellation, ATS shall be deemed to have been damaged to

## ATS Systems Ultimate Chuck Installation and Operations Manual

the extent of, but not limited to, the amount of any deposit held by ATS, and ATS shall retain such deposits as damages, and not as a penalty.

7. **INSTALLATION AND SERVICE:** Installation and all costs relating thereto shall be the responsibility of the Purchaser. If requested, ATS will provide qualified service personnel for installation and/or repair at ATS's then prevailing service rates.
8. **RE-STOCKING:** A 15% minimum re-stocking charge shall apply to all items returned. All returns must be authorized by ATS in writing and are subject to inspection before acceptance. Items ordered special and not normally stocked are non-returnable.
9. **SERVICE ORDERS:** All parts, accessories and tooling orders are subject to a \$30.00 minimum. All service calls are subject to a 4-hour minimum charge.
10. **WARRANTY; DISCLAIMER OF IMPLIED WARRANTIES, LIMITATION OF LIABILITY:**
  - 10.1. The warranties set forth below are the exclusive warranties made by ATS. There are no other warranties, express or implied, by law or usage, which extend beyond the description on the face hereof. Buyer waives all other warranties, express, implied or statutory. ATS makes no warranty of merchantability. The description of goods or repairs contained in this Agreement is for the sole purpose of identifying them, and is not a warranty.
  - 10.2. ATS's liability under the warranty set forth below shall be limited solely to the remedies set forth below. ATS has no responsibility whatsoever for reimbursing Buyer for repair or replacement costs incurred by Buyer in connection with ATS equipment without ATS first having given to Buyer written authorization for such charge.
  - 10.3. ATS's warranties apply only in the event that ATS is given written notice by Buyer of a malfunction or failure of the equipment to perform in a normal way within fifteen (15) days after Buyer discovers a problem, and within the time limits of the applicable warranty. Any action for breach of warranty or other action arising out of purchase of the equipment covered by this agreement must be commenced within one (1) year after such cause of action arises.
  - 10.4. ATS's warranties set forth below apply only with regard to malfunction, failures of the equipment to perform in a normal way, or other problems which are caused by defective material or workmanship in the manufacture of the equipment. The warranties do not apply to damage to the equipment or problems which occur as the result of Buyer's failure to properly use or maintain the equipment or to any other problems with the equipment caused by Buyer or parties other than ATS.
  - 10.5. Express Parts and Service Warranty: ATS's warranties depend on whether or not ATS installs the equipment.
    - 10.5.1. If ATS installs the equipment, then ATS warrants that for a period of one hundred four (104) weeks [for Barfeeders only, one hundred and fifty-six (156) weeks] after shipment of the equipment ATS will do one or both of the following.
      - 10.5.1.1. Without charge, make a prompt investigation of the equipment. Customer testing, or return of the equipment to ATS, may be required as part of this investigation. If ATS determines in its sole judgment that claimed defects were caused by misuse, neglect, improper repair, alteration or accident, ATS shall have no further responsibilities to Buyer.
      - 10.5.1.2. If, after investigating the equipment, ATS finds in its sole judgment that the equipment contains defective material or workmanship, and the same is the cause of the malfunction or failure of the equipment to perform in the normal way, ATS will, at its expense, provide all labor and repairs and/or supply the replacement parts necessary to correct the malfunction or

## ATS Systems Ultimate Chuck Installation and Operations Manual

equipment failure. Buyer shall return defective parts replaced under the Parts and Service Warranty to ATS. If Buyer fails to return defective parts to ATS then Buyer shall pay to ATS its normal price for the replacement parts. The cost of travel, freight and/or other shipping charges for any parts supplied or returned under the Parts and Service Warranty shall be borne by ATS for a period of six months from date of shipment. After six months, the cost of travel and freight is borne by the Buyer.

10.5.2. If ATS does not install the equipment, then ATS warrants that for a period of twenty-six (26) weeks [for collet chucks only, fifty-two (52) weeks] after shipment of the equipment, ATS will do the following.

10.5.2.1. Without charge, make a prompt investigation of the equipment. Customer testing or return of the equipment to ATS may be required as part of this investigation. If ATS determines in its sole judgment that claimed defects were caused by misuse, neglect, improper installation or repair, alteration or accident, ATS shall have no further responsibilities to Buyer.

10.5.2.2. If, after investigating equipment, ATS finds in its sole judgment that the equipment contains defective material or workmanship and that the same is the cause of the malfunction or failure of the equipment to perform in the normal way, ATS will, at its expense, supply such replacement parts as are necessary to correct the malfunction or equipment failure. Buyer will be responsible for returning defective parts replaced under this parts and service warranty, and Buyer's failure to comply will render Buyer liable for the cost of the replacement parts. The cost of freight and/or other shipping charges for any parts supplied or returned under the parts service warranty shall be borne by the Buyer. Buyer shall be responsible for and shall pay ATS for all labor costs incurred by ATS with regard to warranty service in situations in which ATS has not installed the equipment.

10.6. Buyer shall reimburse ATS for all travel, room and board, lodging, and similar expenses incurred by ATS in the course of providing any and all warranty services with regard to the equipment, except during the first six months for equipment installed by ATS as defined above.

10.7. IN NO EVENT SHALL ATS BE LIABLE TO BUYER FOR LOSS OF PROFITS, LOSS OF USE, OR DAMAGE OF ANY KIND BASED UPON CLAIM FOR BREACH OF WARRANTY, OR FOR FAULTY WORKMANSHIP OR MATERIALS, INCLUDING WITHOUT LIMITATION, CONSEQUENTIAL DAMAGES AND INCIDENTAL DAMAGES EXCEPT AS THEY MAY BE IMPOSED BY LAW IN THE CASE OF PERSONAL INJURIES FROM "CONSUMER GOODS".

10.8. ATS's warranties shall not be enlarged, diminished, or affected by, and no obligation or liability shall arise or grow out of ATS's rendering of technical assistance or service in connection with Buyer's order of the equipment furnished under this Agreement.

11. **MODIFICATION OF TERMS AND CONDITIONS:** No addition to or modification of any of these provisions shall be binding upon ATS, unless made in writing and signed by a duly authorized representative of ATS. These provisions constitute the entire agreement of the parties and any terms, oral or written not specified herein shall be binding.

12. **SUCCESSORS:** All terms and conditions set forth herein are and shall be binding upon and inure to the benefit of the parties herein.

13. **ATTORNEYS' FEES:** In the event of litigation with regard to the rights and duties of the parties under these terms and conditions, or interpreting these terms and conditions, the prevailing party shall recover from the losing party all costs of litigation, including reasonable attorneys' fees.



## ATS Systems' Extended Warranty UC2 Quick Jaw Change Chucks and Cylinders

**Customer and Machine Tool Information:**

Company \_\_\_\_\_ City \_\_\_\_\_ State \_\_\_\_\_

Date Installed \_\_\_\_\_ Contact Name \_\_\_\_\_ Title \_\_\_\_\_

Machine Tool Seller (If applicable) \_\_\_\_\_

Machine Installed by (If known) \_\_\_\_\_

Machine Model \_\_\_\_\_ Machine Serial # \_\_\_\_\_

Hydraulic Cylinder Model \_\_\_\_\_

ATS Chuck Model \_\_\_\_\_ ATS Serial # \_\_\_\_\_

ATS Service Engineer \_\_\_\_\_

Congratulations! Your investment in ATS Systems' product includes installation, training and an extended warranty. Proper installation and customer training in operation and maintenance are key to achieving top performance and the best return on your investment. To provide you with the maximum possible benefits we encourage you to participate in all phases of the installation and training. This hands-on experience will give you the knowledge to operate the product safely and efficiently, and will allow easy communication and trouble shooting should you have any problems

**Ultimate Chucks and High-Low cylinders:**

The ATS Systems Installation Assistance and Operator Training Price includes extending the warranty from 6 months parts only to two years parts and labor\* and includes a free custom drawtube adapter sold at \$450. For the first six months, this extended warranty includes freight costs for the replacement of defective parts and Service Engineer travel expenses. After six months, the customer is responsible for all freight and travel costs. Depending on your location and distance from one of our many field service engineers, travel costs may be small.

**ATS Systems will schedule a standard amount of time to complete the installation & training of your operators and maintenance staff. Enlightened customers will be prepared and will provide adequate support and equipment to complete the installation in the standard time so as to allow ample time to receive maximum training and resulting benefits.**

**\* ATS Systems' Two-Year Warranty**

**Please note that ATS Systems' warranty does not cover damage due to accident, misuse or operator neglect; rubber components, seals or gaskets which are subject to wear and damage caused by misuse.**

**Customer Warranty Acknowledgement**

I have reviewed and understand the warranty for this product.

Customer Name \_\_\_\_\_ Position \_\_\_\_\_

Customer Signature \_\_\_\_\_ Date \_\_\_\_\_

**Customer Training Acknowledgement**

I have been adequately trained on this product and completely understand the requirements to operate them safely.

Customer Name \_\_\_\_\_ Position \_\_\_\_\_

Customer Signature \_\_\_\_\_ Date \_\_\_\_\_



## Ultimate Chuck UC2 Installation and Customer Training Checklist

**Note: All items with signature box must be initialed by ATS Systems Service Engineer.**

**General Inventory Checklist - ATS supplied items** (See BOM for details of this specific order):

- |   |  |  |
|---|--|--|
| <input type="checkbox"/> Chuck            | <input type="checkbox"/> manual                  | <input type="checkbox"/> maintenance decal |
| <input type="checkbox"/> Drawtube adapter | <input type="checkbox"/> grease gun & grease     | <input type="checkbox"/> Jaw change wrench |
| <input type="checkbox"/> Wrench-drawtube  | <input type="checkbox"/> bolts- chuck to spindle |  |

### Key Checks Before Proceeding:

- Get list of people to train and name of management contact to advise of any safety or other issues.
- Check that lathe spindle nose is the same as the chuck provided.
- Machine top speed is lower than rated speed of chuck, or soft limit is set.
- Are top jaws available for first job? Check jaw fit on base jaws.
- Is material available for first job?

### Installation Steps: Manual section 3

- Attach safety/maintenance decal to lathe.
- Remove existing chuck. Actuate the chuck and hit the e-stop in mid-stroke. This will cause an alarm and shutoff the machine hydraulics for easy removal of chuck. Clean spindle nose and flange, remove defects with a stone.
- Make sure the drawtube is screwed in tight to the cylinder.
- Screw the drawtube adapter all the way on to the drawtube to inspect proper threads. Retract the drawtube to ensure the drawtube adapter will fit into the bore of the spindle.
- Measure the length from the spindle flange face to the end of the drawtube. It must be shorter than the respective dimension in the back of the chuck. Check with drawtube in forward position, chuck piston in the forward open position.
- Measure actual drawtube stroke and record. \_\_\_\_\_  
For reference: \* Below, minimum drawtube stroke to use hard jaws and avoid need for 1/2 pitch base jaws assuming drawtube length is perfectly adjusted. You would like to have more stroke than this to allow for some drawtube length adjustment tolerance. Explain this to the customer if it's close.

UC2 Model	170	210	225	265	315	400	500	630
Full piston stroke	.71	.79	.79	1.10	1.10	1.18	1.38	1.57
Min. stroke for hard jaws*	.71	.76	.76	.85	.85	.85	1.1	1.1



- Complete and attach to the machine the “Chuck and Cylinder Specifications” decal with all engineering data and fill in all data on the copy on pg. 8 of this checklist. You’ll need to get cylinder and lathe hydraulic specs off the machine or in the machine manuals. Call Santa Fe Springs for help.
- If drawtube stroke is less than "Min stroke for hard jaws" shown above, advise user management (in addition to training the shop staff) they will need half pitch base jaws for hard jaw applications and to take care that they are always gripping in the first part of the jaw stroke. If stroke is longer but close, advise them to regularly check drawtube adjustment and jaw stroke. Measure and record actual jaw stroke below.
- If available machine pressure and resulting drawbar pull exceeds chuck limit, advise user management not to exceed limit. Suggest customer obliterate pressure information on lathe builder decals that apply to other chucks to avoid confusion.
- \_\_\_ Check runout of spindle nose taper and flange. Max allowable .0002” TIR. Actual \_\_\_\_\_"TIR.
- \_\_\_ Check drive button counterbore depth and make sure it is deeper than spindle drive button.
- \_\_\_ Inspect UC2 chuck. Clean mating surfaces. Stone to remove any imperfections.
- Check that mounting bolts are correct length to provide minimum 1.5x diameter engagement and are grade 12.9 if metric, grade 8 if inch. *Note: Some spindle flanges have thru tapped holes and bolts too long could damage seals or bearings.*
- \_\_\_ Place a light film of KO5 grease on drawtube adapter end and insert into chuck. Loctite drawtube adapter locking into chuck using service removable (blue) Loctite. Adapter must turn freely in chuck without any restrictions and have no vertical movement of any kind.
- \_\_\_ With the drawtube fully retracted and the chuck piston forward mount the chuck to the spindle and tighten the bolts. Screw the chuck adapter fully onto the drawtube with the wrench provided. With the chuck in the open position unscrew the adapter until it will not rotate. The chuck should now be mounted and the drawtube length correct for jaw stroke and jaw change.
- \_\_\_ Check operation of drawtube and jaw change. If necessary, adjust drawtube adapter a half turn at a time until cam bolts turn with hex key and jaw stroke is to spec. If this is not set correctly, jaw change will be difficult. See manual 3.1.2
- Measure actual jaw stroke and record. \_\_\_\_\_”. Confirm it is either full stroke or proportional to short stroking cylinder noted above.
- \_\_\_ Inspect chuck concentricity on the OD indicating surface, and face runout.  
Record actual runouts: OD \_\_\_\_\_TIR; Face \_\_\_\_\_TIR
- \_\_\_ Using the dynamic grip force gauge, inspect the grip force at either the maximum available hydraulic pressure, or the maximum allowable pressure for this cylinder that yields the maximum allowable drawbar pull. (Refer to the “Chuck and Cylinder Specifications” decal you completed.) Compare your gauge reading to a calculated grip force.

Chuck model/size	170	210	225	265	315	400	500	630
Max. drawbar pull – lb.	7,400	11,240	11,240	16,410	22,480	29,890	29,890	29,890
Max. total grip force- lb	13,480	21,350	21,350	30,350	40,460	53,950	53,950	53,950

Later, demonstrate gauge during training session and recommend purchase of gauge.

### Training Checklist:

Customer Employees Trained Include:

\_\_\_\_\_

\_\_\_\_\_

### Operator and supervisor training:

**Present all words in this section not shown in italics.** *And, add your own words and explanations to make each point clear.*

High speed lathes and chucks are perhaps the most hazardous equipment in most machine shops. Lathes and chucks have been designed and built with your safety in mind and have many safety features, guards and interfaces. But, the only way to prevent accidents and possible injury is to understand the hazards and to follow all the proper rules, recommendations, and general and specific safe shop practices. People are regularly injured and even killed as a result of "accidents" involving chucks. 99% of the time the accident is the result of operator error or lack of experience and training, not as a result of any failure of the equipment. Please listen carefully, ask questions and refuse to operate this equipment if you are unsure how to operate it safely. The life you save may be your own.

**The bad things that can happen and the most common causes.**

1. If a jaw were to come off of a spinning chuck it will become a projectile traveling in a straight line and could penetrate the heaviest guard. There is a high likelihood of serious injury here and fatalities are not uncommon.

Possible causes:

- Bolts too short, inadequate thread engagement, threads strip off.
- Bolts not properly torqued tight and come loose.
- Wrong grade of bolts and they break.
- Excessively tall jaws and even moderate grip forces can put severe tension on bolts and cause them to break.
- RPM way too high for an oversize jaw and the bolts actually shear. (Watch out when using constant surface feet programming!)
- Base jaw not engaged to "Safe" zone
- Poor quality or poor design jaw actually breaks and a portion of the jaw becomes a projectile. An example would be some types of welded jaws, cast jaws that can break, or a hard jaw that is improperly hardened (through hardened) and becomes brittle.

2. If a part is not securely clamped it can be thrown from the chuck. Unless it is struck by a spinning jaw as it exits it will not be traveling in a straight line and there is a good chance a heavy guard will stop it but it may not. Fatal accidents have happened.

Possible causes:

- RPM too high for the jaw selected, loss of grip force due to centrifugal force, part is released.
- Part inadequately gripped due to lack of proper chuck lubrication and resulting low grip force.
- Part inadequately gripped and pulled from jaw by an aggressive cutting tool.
- Part inadequately gripped due to poor choice of top jaw and pulled from jaw by even light cutting tool force. (Such as soft jaws gripping an irregular rough casting.)
- Jaw positioned incorrectly or major workpiece gripping diameter variation (castings) causes jaw stroke to reach bottom before properly gripping the workpiece. (Some lathes with some styles of stroke control will protect from this.)
- Part inadequately gripped because the hydraulic pressure and resulting grip force is too low for the application.

- The chuck actually breaks at some critical component either because the drawbar pull is way over the maximum rating, or the chuck is used and fatigued for an extended time at a drawbar pull that is perhaps only 20% over the maximum rating.

Now that I have your attention, we will go step by step through the safe operating practices of the Ultimate Chuck. Note that all of what I've just said about the hazards and what I will now say about how to deal with them applies to all jaw chucks, not just the Ultimate Chuck.

- I have attached this maintenance and safety decal to your lathe. It summarizes the points I will now cover and I encourage you to review it regularly.
- This is the Installation, Operation and Maintenance Manual. It contains all the information I am going to present and more. Please read it carefully and pay special attention to safety items in sections 1.1 through 1.3.8, safe jaw positioning in section 4.2, calculating safe operating speed for different top jaws in section 4.4, and proper lubrication in section 5.2.

My training will now cover the following topics:

1. Safe chuck speed.
2. Changing, positioning and mounting jaws for safe operation.
3. Proper chuck lubrication.
4. Hydraulic pressure and proper drawbar / drawtube pull.
5. Chuck inspection and some miscellaneous safety instructions.

- Safe chuck speed (RPM) is greatly influenced by the top jaws used. The maximum rated speed of this chuck is \_\_\_\_ and applies only for normal chucking applications using the maximum rated drawbar pull and only for standard top jaws such as our Deep Bite Job Shop Jaw. For any other top jaws or conditions, speed must be reduced. (*Manual 2.2*)

Always use the smallest, lightest, shortest jaw possible, and position it as close to centerline as possible. Centrifugal force pulls on all jaws and reduces actual grip force. The further out from centerline and the heavier the jaw, the higher the centrifugal force. When you do use oversize jaws or even standard jaws if they are positioned very far out from centerline, you need to determine a safe operating speed. You can either do this by using a dynamic grip force gauge and slowly raise the RPM until 50% of the initial grip force remains, or you can weigh the master base jaw and top jaw combination and make some simple calculations as shown in the manual section 4.4. *Demonstrate how to remove the bolted together base and top jaw, to weigh it, to balance it in a knife edge to determine and mark the center of gravity, to reinstall the jaw and measure the distance from centerline to the CG of the jaw assembly when the jaw is in the proper position for the particular job, and how to make the calculations by taking them either through their actual setup or examples #3 and #4 in the manual section 4.4.*

4.4

Note that you can also use this technique and formulas to calculate the approximate safe speed of standard chucks, but you must weigh and measure not only the top jaw but also the master jaw, bolts and T-nuts as an assembly. If you don't include the master jaws you will calculate a speed that's way too high. Of course, this requires you to disassemble the chuck which is impractical. (*Another selling benefit of the Ultimate Chuck.*)

**Are there any questions?**

- Now I want to talk about changing jaws, positioning jaws and bolting on jaws for safe operation.  
4.1 - First, only use this special wrench to change jaws. A standard wrench will damage the chuck.



- 4.1 - Never leave the wrench in the chuck.. If you start the lathe, the wrench can fly out and hit you. If you actuate the chuck with the wrench in, the chuck will be damaged.
- 1.3.6- Only use jaw mounting bolts that are marked grade 12.9, with threads in new condition, and long enough to engage a thread length 1 ½ - 2 times the diameter. Torque the bolts to the specification as shown in the manual (*Chuck size 170-225 M8 24 ft-lb; 265-400 M12 80 ft lb; 500-63 M16 180 ft lb.*) If you over torque, the base jaw may distort slightly and won't slide easily in the guideway.
- 4.2 - Always position the inside end of the base jaw or monoblok jaw inside the "Safe" zone marked on the face of the chuck. Don't ever extend base jaws beyond this limit, and don't ever position any top jaw beyond the OD of the chuck more than a standard base jaw would extend when it is within the safe zone. *Demonstrate installing a jaw, point to the safe zone.*
  - Finally on the subject of positioning jaws, always position the jaw to grip the workpiece as close to the start of the jaw stroke as possible. The issue isn't that the chuck needs to operate near the start of the stroke, the issue is that you want to have extra stroke available in case one of your workpiece blanks is much smaller diameter than the blank you setup with. With the cylinder on this lathe, this chuck has a jaw stroke of \_\_\_\_". The adjustment pitch is \_\_\_\_ ". The maximum jaw stroke for this chuck is \_\_\_\_", so with this cylinder we are short stroking .....(*a little bit, a lot, whatever describes this installation.*)

UC2 Model	170	210	225	265	315	400	500	630
Adjustment	.189	.189	.189	.216	.216	.216	.275	.275
Max. Stroke	.22	.25	.25	.35	.36	.39	.45	.50

So when using hard jaws on this machine:

- a. (*if the jaw stroke exceeds the adj. pitch more than .040"*) you might find two possible jaw positions that work. If so, choose the one that grips close to the start of the stroke.
- b. (*if the jaw stroke is short*) you will need to purchase a set of half-pitch base jaws and when necessary switch with your normal base jaws to grip close to the start of the jaw stroke.

It is very important that each time you chuck a part you note if you are near the end of the jaw stroke and risk not properly holding the part. If this happens, adjust all three jaws in one step and use half-pitch base jaws if necessary. (*This point may be a bit confusing, so spend as much time as necessary until everyone understands.*)

- **Are there any questions?**

- Lubrication is important on any chuck. On this high-tech, high performance chuck it is particularly important. See manual sections 5.2 and 1.3.5.

- Unless the chuck is properly lubricated your grip force might only be 50% of what it would be with proper lubrication. You could throw parts.
- Use only ATS Systems' KO5 grease. Grease chuck every 24 hours of operation, two shots of KO5 per grease fitting with the chuck in the full "open-jaws out" position.
- Fully stroke the chuck (10) times after lubricating to distribute grease to internal components.
- At the start of each shift and after every 50 clamping cycles, actuate the chuck full stroke 5-10 times without gripping a workpiece to internally redistribute grease throughout the chuck.
- Clean jaw guideways when changing jaws, or at least once per shift if no jaw change is required, and lightly coat sliding jaw surfaces with KO5. (*Demonstrate sweeping chips out of the guideway located at the 6:00 position.*)



- With the cylinder that is on this machine, (decide if comment "a" or "b" below is appropriate. Usually it's "a". A "b" condition is rare.)
- a. and with the maximum hydraulic pressure the machine has available, this chuck is operating at \_\_\_ % of it's maximum rated grip force. Note that the Ultimate Chuck's maximum grip force is probably 1.2-1.5 times that of a standard chuck and anything above 65% is typical. Also, to get the same static grip force as the standard chuck you need to increase the pressure 30%. So if you have pressure settings recorded for jobs you run on this machine, increase them by 30% up to the maximum. If you can't achieve the static grip force you had before it's probably not a problem. What you need isn't static grip force when the chuck isn't rotating, but remaining grip force when you are at cutting speed. Do the calculations for the jaws you are using or use a grip force gauge and limit your speed to a 50% grip force loss.
  - b. the maximum hydraulic pressure the machine has available would give too much drawbar pull for this chuck and the chuck would be damaged. Because of this I've noted on this tag that the pressure should never be set above \_\_\_ PSI. For most any application you shouldn't need more than 90% of that pressure.

### Any questions?

- Finally for some miscellaneous points.
- Never stand in line with a rotating chuck. Always stand off to one side so that if anything bad happens it's less likely to hit you.
- 1.3.5- I recommend you purchase a dynamic grip force gauge and inspect the grip force of the chuck weekly and record it. If you note a decrease in grip force it's time to disassemble, clean and inspect the chuck. Under normal operating conditions it's wise to clean the chuck every 1000- 1500 hours of operation.
- So, for a quick review:**
- \_\_\_ Avoid standing directly in line with a rotating chuck or workpiece.
  - \_\_\_ Don't forget the hazard of using non standard large jaws and even full wide soft jaws. Resulting centrifugal force may require RPM to be limited.
  - \_\_\_ Use only grade 12.9 bolts in new condition for jaw mounting with a minimum of 1½ -2 times diameter thread engagement.
  - \_\_\_ Use only the special ATS hex key to change jaws or chuck will be damaged. Never take your hand off the key. Never leave key in the chuck as it could fly out if spindle is rotated.
  - \_\_\_ Increase hydraulic pressure 30% to achieve same static grip force as most standard chucks.
  - \_\_\_ Always position the end of the base jaw inside the safe zone marked on the face of the chuck.
  - \_\_\_ Set jaw adjustment to grip the part as close to the start of the jaw stroke as possible, especially when chucking irregular castings, forgings, etc. As you chuck each part, observe that adequate jaw stroke remains to grip the part.
  - \_\_\_ If drawtube stroke and resulting jaw stroke is less than .050" more than the adjustment pitch, you need to use half pitch base jaws for hard jaw applications and to take care that you always setup to grip in the first part of the jaw stroke.
  - \_\_\_ Chuck lubrication
    - Lubricate every 24 hours of operation with two shots of KO5 grease per fitting.
    - Lubricate with chuck in the fully open (jaws away from centerline) position only.
    - Fully stroke chuck (10) times after lubricating to distribute grease to internal components.
    - Fully stroke the chuck 5-10 times after each 50 parts and at the start of the shift
    - Clean and lubricate jaws whenever jaws are changed, or once per eight hour shift.



- If ATS supplied the hydraulic cylinder, demonstrate the stroke control system. Spindle should not turn under power unless a part is chucked and jaws are not fully open or fully closed. If ATS cylinder, note here if lathe has no such system and advise customer management you could not interface.  
*Name of person advised:* \_\_\_\_\_

- \_\_\_ Boring soft jaws. Manual section 4.3  
\_\_\_ Train customer on the features and benefits of the chuck (many operators don't know).  
\_\_\_ Train on the types of jaws available and typical applications (how to use the jaw catalog).  
\_\_\_ Review recommended spare parts list.

### Installers Evaluation:

- \_\_\_ Rate your opinion of the customer's grasp of the training, and his potential to operate and maintain the product properly. (1-10)



## ULTIMATE CNC CHUCK AND LATHE CYLINDER SPECIFICATIONS FOR THIS INSTALLATION

Chuck Model \_\_\_\_\_ Cylinder Model \_\_\_\_\_

Max. Chuck piston stroke = \_\_\_\_\_" Max. Cylinder piston stroke = \_\_\_\_\_"

Max. Chuck jaw stroke = \_\_\_\_\_" Jaw stroke with this Cylinder = \_\_\_\_\_"  
(If jaw stroke is less than maximum, use half pitch base  
jaws as required for hard jaw applications.)

Max. allowable Cylinder pressure = \_\_\_\_\_ psi.

Max. Cylinder pull = \_\_\_\_\_ lbs. at max. pressure.

Max. available machine pressure = \_\_\_\_\_ psi.

Max. Chuck drawbar pull = \_\_\_\_\_ lbs. Cylinder pull at max machine pressure = \_\_\_\_\_ lbs.

- If cylinder pull at maximum machine pressure exceeds maximum chuck drawbar pull:

**Limit cylinder pressure to \_\_\_\_\_ psi or damage to chuck will occur.**

- If cylinder pull at maximum machine pressure is less than maximum chuck drawbar pull:

**With this cylinder at the maximum available machine pressure, the chuck develops \_\_\_\_\_ % of its maximum possible grip force.**

**ATS Systems (800) 423-4651**